

Warranty	5
Safety Symbols	6
WARNINGS	6
Declaration of Conformity	7
Chapter 1	
Configuring the HP E8460A Multiplexer	11
Using This Chapter	11
Module Description	11
Relay Organization	11
Analog Bus	12
Terminal Cards	12
Warnings and Cautions	14
Configuring the Multiplexer Module	15
Setting the Logical Address	15
Setting the Interrupt Priority Line	16
Protection Resistors	16
Installing the Multiplexer in a Mainframe	17
Connecting Field Wiring	18
Terminal Connector Blocks	18
Connecting the Analog Bus	22
Terminal Cards	23
Programming the Multiplexer	29
Specifying SCPI Commands	29
Channel Address	29
Card Numbers	30
Channel Numbers, Ranges, and Lists	31
Initial Operation	32
Example: Reset, Self Test, Module ID, and Close Channel	33
Chapter 2	
Using the Multiplexer	35
What's in This Chapter	35
Reset Conditions	35
Switching or Scanning	36
Switching Channels to the Analog Bus	36
1-Wire Mode	39
2-Wire Mode	40
3-Wire and 4-Wire Modes	41
Other Modes	41
Maximum Relay Closures	41
Eight 32 x 1 Multiplexers	43
Sixteen 16 x 1 Multiplexers	44
Scanning Channels	45
Recalling and Saving States	53
Saving States	53
Recalling States	53
Detecting Error Conditions	54
Using Interrupts With Error Checking	54

Chapter 3

Multiplexer Command Reference	55
Using This Chapter	55
Command Types	55
Common Command Format	55
SCPI Command Format	55
ABORt	58
ARM	60
ARM:COUNT	60
ARM:COUNT?	60
DIAGnostic	61
DIAGnostic:INTerrupt[:LINE]	61
DIAGnostic:INTerrupt[:LINE]?	62
DIAGnostic:CLOSe	62
DIAGnostic:CLOSe?	63
DIAGnostic:OPEN	64
DIAGnostic:OPEN?	65
DIAGnostic:TEST?	65
INITiate	66
INITiate:CONTinuous	66
INITiate:CONTinuous?	67
INITiate[:IMMediate]	67
OUTPut	68
OUTPut:ECLTrgn[:STATe]	68
OUTPut:ECLTrgn[:STATe]?	68
OUTPut[:EXTernal][:STATe]	69
OUTPut[:EXTernal][:STATe]?	69
OUTPut:TTLTrgn[:STATe]	70
OUTPut:TTLTrgn[:STATe]?	70
[ROUTE:]	71
[ROUTE:]CLOSe	71
[ROUTE:]CLOSe?	73
[ROUTE:]FUNCTion	74
[ROUTE:]FUNCTion?	75
[ROUTE:]OPEN	75
[ROUTE:]OPEN?	76
[ROUTE:]SCAN	76
[ROUTE:]SCAN:MODE	77
[ROUTE:]SCAN:MODE?	78
[ROUTE:]SCAN:PORT	78
[ROUTE:]SCAN:PORT?	79
STATus	80
STATus:OPERation:CONDition?	81
STATus:OPERation:ENABLE	81
STATus:OPERation:ENABLE?	81
STATus:OPERation[:EVENT]?	82
STATus:PRESet	82
SYSTEM	84

SYSTem:CDEscription?	84
SYSTem:CPON	84
SYSTem:CTYPe?	85
SYSTem:ERRor?	85
TRIGger	86
TRIGger[:IMMediate]	86
TRIGger:SOURce	87
TRIGger:SOURce?	88
SCPI Command Quick Reference	89
IEEE 488.2 Common Command Reference	90

Appendix A

HP E8460A Specifications	91
General Characteristics	91
Input Characteristics	92
Maximum Input	92
DC Performance	
(Typical)	92
AC Performance	
(Typical)	93
Relay Life	94

Appendix B

Register-Based Programming	95
About This Appendix.....	95
Register Addressing.....	95
The Base Address	95
Register Offset	98
Register Descriptions.....	99
ID Register	100
Device Type Register	100
Status/Control Register	100
Relay Control Registers	102
Program Timing and Execution.....	106
Closing Channels	106
Using a Multimeter with the Multiplexer	107
Programming Example	108
System Configuration	108
Example Program	108

Appendix C

Error Messages	115
Error Types	115

HEWLETT-PACKARD WARRANTY STATEMENT

HP PRODUCT: HP E8460A 256-Channel Relay Multiplexer **DURATION OF WARRANTY:** 3 years

1. HP warrants HP hardware, accessories and supplies against defects in materials and workmanship for the period specified above. If HP receives notice of such defects during the warranty period, HP will, at its option, either repair or replace products which prove to be defective. Replacement products may be either new or like-new.
2. HP warrants that HP software will not fail to execute its programming instructions, for the period specified above, due to defects in material and workmanship when properly installed and used. If HP receives notice of such defects during the warranty period, HP will replace software media which does not execute its programming instructions due to such defects.
3. HP does not warrant that the operation of HP products will be interrupted or error free. If HP is unable, within a reasonable time, to repair or replace any product to a condition as warranted, customer will be entitled to a refund of the purchase price upon prompt return of the product.
4. HP products may contain remanufactured parts equivalent to new in performance or may have been subject to incidental use.
5. The warranty period begins on the date of delivery or on the date of installation if installed by HP. If customer schedules or delays HP installation more than 30 days after delivery, warranty begins on the 31st day from delivery.
6. Warranty does not apply to defects resulting from (a) improper or inadequate maintenance or calibration, (b) software, interfacing, parts or supplies not supplied by HP, (c) unauthorized modification or misuse, (d) operation outside of the published environmental specifications for the product, or (e) improper site preparation or maintenance.
7. TO THE EXTENT ALLOWED BY LOCAL LAW, THE ABOVE WARRANTIES ARE EXCLUSIVE AND NO OTHER WARRANTY OR CONDITION, WHETHER WRITTEN OR ORAL, IS EXPRESSED OR IMPLIED AND HP SPECIFICALLY DISCLAIMS ANY IMPLIED WARRANTY OR CONDITIONS OF MERCHANTABILITY, SATISFACTORY QUALITY, AND FITNESS FOR A PARTICULAR PURPOSE.
8. HP will be liable for damage to tangible property per incident up to the greater of \$300,000 or the actual amount paid for the product that is the subject of the claim, and for damages for bodily injury or death, to the extent that all such damages are determined by a court of competent jurisdiction to have been directly caused by a defective HP product.
9. TO THE EXTENT ALLOWED BY LOCAL LAW, THE REMEDIES IN THIS WARRANTY STATEMENT ARE CUSTOMER'S SOLE AND EXCLUSIVE REMEDIES. EXCEPT AS INDICATED ABOVE, IN NO EVENT WILL HP OR ITS SUPPLIERS BE LIABLE FOR LOSS OF DATA OR FOR DIRECT, SPECIAL, INCIDENTAL, CONSEQUENTIAL (INCLUDING LOST PROFIT OR DATA), OR OTHER DAMAGE, WHETHER BASED IN CONTRACT, TORT, OR OTHERWISE.

FOR CONSUMER TRANSACTIONS IN AUSTRALIA AND NEW ZEALAND: THE WARRANTY TERMS CONTAINED IN THIS STATEMENT, EXCEPT TO THE EXTENT LAWFULLY PERMITTED, DO NOT EXCLUDE, RESTRICT OR MODIFY AND ARE IN ADDITION TO THE MANDATORY STATUTORY RIGHTS APPLICABLE TO THE SALE OF THIS PRODUCT TO YOU.

U.S. Government Restricted Rights

The Software and Documentation have been developed entirely at private expense. They are delivered and licensed as "commercial computer software" as defined in DFARS 252.227- 7013 (Oct 1988), DFARS 252.211-7015 (May 1991) or DFARS 252.227-7014 (Jun 1995), as a "commercial item" as defined in FAR 2.101(a), or as "Restricted computer software" as defined in FAR 52.227-19 (Jun 1987)(or any equivalent agency regulation or contract clause), whichever is applicable. You have only those rights provided for such Software and Documentation by the applicable FAR or DFARS clause or the HP standard software agreement for the product involved.



HP E8460A 256-Channel Multiplexer User's Manual and SCPI Programming Guide
Edition 2
Copyright © 1998 Hewlett-Packard Company. All Rights Reserved.

Documentation History

All Editions and Updates of this manual and their creation date are listed below. The first Edition of the manual is Edition 1. The Edition number increments by 1 whenever the manual is revised. Updates, which are issued between Editions, contain replacement pages to correct or add additional information to the current Edition of the manual. Whenever a new Edition is created, it will contain all of the Update information for the previous Edition. Each new Edition or Update also includes a revised copy of this documentation history page.

Edition 1 July 1997

Edition 2 April 1998

Safety Symbols



Instruction manual symbol affixed to product. Indicates that the user must refer to the manual for specific WARNING or CAUTION information to avoid personal injury or damage to the product.



Indicates the field wiring terminal that must be connected to earth ground before operating the equipment. Protects against electrical shock in case of fault.

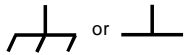

Frame or chassis ground terminal—typically connects to the equipment's metal frame.



Alternating current (AC)



Direct current (DC).

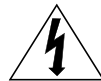

Indicates hazardous voltages.

WARNING

Calls attention to a procedure, practice, or condition that could cause bodily injury or death.

CAUTION

Calls attention to a procedure, practice, or condition that could possibly cause damage to equipment or permanent loss of data.

WARNINGS

The following general safety precautions must be observed during all phases of operation, service, and repair of this product. Failure to comply with these precautions or with specific warnings elsewhere in this manual violates safety standards of design, manufacture, and intended use of the product. Hewlett-Packard Company assumes no liability for the customer's failure to comply with these requirements.

Ground the equipment: For Safety Class 1 equipment (equipment having a protective earth terminal), an uninterruptible safety earth ground must be provided from the mains power source to the product input wiring terminals or supplied power cable.

DO NOT operate the product in an explosive atmosphere or in the presence of flammable gases or fumes.

For continued protection against fire, replace the line fuse(s) only with fuse(s) of the same voltage and current rating and type. DO NOT use repaired fuses or short-circuited fuse holders.

Keep away from live circuits: Operating personnel must not remove equipment covers or shields. Procedures involving the removal of covers or shields are for use by service-trained personnel only. Under certain conditions, dangerous voltages may exist even with the equipment switched off. To avoid dangerous electrical shock, DO NOT perform procedures involving cover or shield removal unless you are qualified to do so.

DO NOT operate damaged equipment: Whenever it is possible that the safety protection features built into this product have been impaired, either through physical damage, excessive moisture, or any other reason, REMOVE POWER and do not use the product until safe operation can be verified by service-trained personnel. If necessary, return the product to a Hewlett-Packard Sales and Service Office for service and repair to ensure that safety features are maintained.

DO NOT service or adjust alone: Do not attempt internal service or adjustment unless another person, capable of rendering first aid and resuscitation, is present.

DO NOT substitute parts or modify equipment: Because of the danger of introducing additional hazards, do not install substitute parts or perform any unauthorized modification to the product. Return the product to a Hewlett-Packard Sales and Service Office for service and repair to ensure that safety features are maintained.

Declaration of Conformity
according to ISO/IEC Guide 22 and EN 45014

Manufacturer's Name: Hewlett-Packard Company
Loveland Manufacturing Center

Manufacturer's Address: 815 14th Street S.W.
Loveland, Colorado 80537

declares, that the product:

Product Name: 256-Channel Relay Multiplexer

Model Number: HP E8460A

Product Options: All

conforms to the following Product Specifications:

Safety: IEC 1010-1 (1990) Incl. Amend 2 (1996)/EN61010-1 (1993)
CSA C22.2 #1010.1 (1992)
UL 3111-1 (1994)

EMC: CISPR 11:1990/EN55011 (1991): Group 1 Class A
EN6100-3-2:1995 Class A
EN50082-1:1992
IEC 801-2:1991: 4kVCD, 8kVAD
IEC 801-3:1984: 3 V/m
IEC 801-4:1988: 1kV Power Line, 0.5kV Signal Lines
ENV50141:1993/prEN50082-1 (1995): 3 Vrms
ENV50142:1994/prEN50082-1: 1kV CM, 0.5kV DM
EN61000-4-8:1993/prEN50082-1 (1995): 3 A/M
EN61000-4-11:1994/prEN50082-1 (1995): 30%, 10mS 60%, 100mS

Supplementary Information: The product herewith complies with the requirements of the Low Voltage Directive 73/23/EEC and the EMC Directive 89/336/EEC (inclusive 93/68/EEC) and carries the "CE" mark accordingly.

Tested in a typical configuration in an HP C-Size VXI mainframe.

May 6, 1997

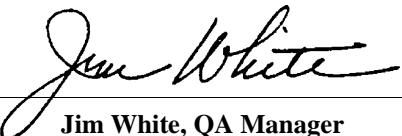

Jim White, QA Manager

European contact: Your local Hewlett-Packard Sales and Service Office or Hewlett-Packard GmbH, Department HQ-TRE, Herrenberger Straße 130, D-71034 Böblingen, Germany (FAX +49-7031-14-3143)

Notes:

Please fold and tape for mailing

Reader Comment Sheet

HP E8460A User's Manual and SCPI Programming Guide

Edition 2

You can help us improve our manuals by sharing your comments and suggestions. **In appreciation of your time, we will enter you in a quarterly drawing for a Hewlett-Packard Palmtop Personal Computer** (U.S. government employees are not eligible for the drawing).

_____	_____
Your Name	City, State/Province
_____	_____
Company Name	Country
_____	_____
Job Title	Zip/Postal Code
_____	_____
Address	Telephone Number with Area Code

Please list the system controller, operating system, programming language, and plug-in modules you are using.

fold here

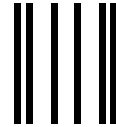

NO POSTAGE
NECESSARY
IF MAILED
IN THE
UNITED STATES

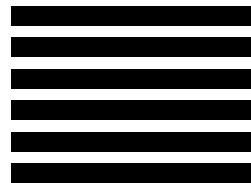

BUSINESS REPLY MAIL
FIRST CLASS PERMIT NO. 37 LOVELAND, CO

POSTAGE WILL BE PAID BY ADDRESSEE

HEWLETT-PACKARD COMPANY

Measurement Systems Division
Learning Products Department
P.O. Box 301
Loveland, CO 80539-9984



fold here

Please pencil-in one circle for each statement below:

- The documentation is well organized.
- Instructions are easy to understand.
- The documentation is clearly written.
- Examples are clear and useful.
- Illustrations are clear and helpful.
- The documentation meets my overall expectations.

Disagree ←————→ Agree

<input type="radio"/>	<input type="radio"/>	<input type="radio"/>	<input type="radio"/>	<input type="radio"/>
<input type="radio"/>	<input type="radio"/>	<input type="radio"/>	<input type="radio"/>	<input type="radio"/>
<input type="radio"/>	<input type="radio"/>	<input type="radio"/>	<input type="radio"/>	<input type="radio"/>
<input type="radio"/>	<input type="radio"/>	<input type="radio"/>	<input type="radio"/>	<input type="radio"/>
<input type="radio"/>	<input type="radio"/>	<input type="radio"/>	<input type="radio"/>	<input type="radio"/>
<input type="radio"/>	<input type="radio"/>	<input type="radio"/>	<input type="radio"/>	<input type="radio"/>

Please write any comments or suggestions below—be specific.

cut along this line

Configuring the HP E8460A Multiplexer

Using This Chapter

This chapter provides general module information, vital WARNINGS and CAUTIONS, and the tasks you must perform to configure and install the HP E8460A Relay Multiplexer. It also provides information to verify the module installation. Chapter contents are:

- Module Description Page 11
- Warnings and Cautions Page 12
- Configuring the Multiplexer Module Page 15
- Installing the Multiplexer in a Mainframe Page 17
- Connecting Field Wiring Page 18
- Terminal Cards Page 23
- Programming the Multiplexer Page 29
- Initial Operation Page 32

Module Description

Figure 1-1 shows the simplified block diagram of the HP E8460A, the Option 015 Ribbon Cable Connector Terminal Card, and a simple measurement application. Notice the sixteen 100 Ω protection resistors; one in series with each bank line. Refer to Figure 1-1 for the following description.

Relay Organization

The HP E8460A Relay Multiplexer is organized as 16 banks (Bank 0 through Bank 15) of 16 channels each (Channel 000 - Ch 015, Ch 016 - Ch 031, Ch 032 - Ch 047, ... Ch 240 - Ch 255). The default configuration is for 256 channels of 1-wire switches.

Tree relays T1 through T48 (Channel 300 through Channel 347) configure the module to the desired operating mode: 1-wire, 2-wire, 3-wire and 4-wire modes. In addition, the tree relays can configure this module as eight 32 x 1 or sixteen 16 x 1 multiplexers.

Relays T49 through T52 (Channels 990 through 994) are the analog bus connection control relays which connect the terminal busses to the analog bus.

Analog Bus

The “Analog Bus Front Panel Connector” on the module allows you to connect this Multiplexer to an VXI multimeter (such as the HP E1411A/B and/or E1326A/B) directly.

The optional Fault Tolerant Terminal Card (Option 014) distributes the analog bus from P109 in the Terminal Card. You can connect this Multiplexer to an HP E1412A Multimeter or other instruments via a ribbon cable (not supplied).

Terminal Cards

No terminal card or connectors are supplied with the HP E8460A. You may purchase 160-pin terminal blocks (order HP part number 1252-6531 or direct from the manufacturer ERNI pn 024070¹) and the necessary crimp-and-insert contacts (HP pn for one contact is 1252-6533A, or ERNI pn 014728). You will also need a crimp tool (HP pn 8710-2306 or ERNI pn 014374) and optionally a disassembly tool (HP pn 8710-2307 or ERNI pn 471555).

You may also purchase one of the three optional terminal cards from HP:

- Option 012 Crimp & Insert Terminal Card uses the same terminal block and crimp connectors described above but provides strain relief and a terminal card housing. Refer to Option 012 Crimp-and-Insert Terminal Block on page 23.
- Option 014 Fault Tolerant Terminal Card provides nine ribbon-cable header connectors (P101-P109). P101 through P108 contain 16 terminals (Ter0 through Ter15) and all the 256 channels (CH000-CH255) and P109 is the analog bus connector. Refer to Option 014 Fault Tolerant Terminal Block on page 23.
- Option 015 Ribbon Cable Connector Terminal Card provides nine ribbon-cable header connectors (P101-P109) identical to option 014. This terminal module is identical to the option 014 terminal module except that the PTC resistors (fault tolerant protection resistors) are replaced with shorts. All this terminal card provides is a convenient means to connect ribbon cable from field wiring to the module.

1. Contact ERNI Components, A Division of ODIN Components, Inc. 520 Southlake Blvd., Richmond, VA 23236, U.S.A. Telephone, (804) 794-6367, FAX (804) 379-2109.

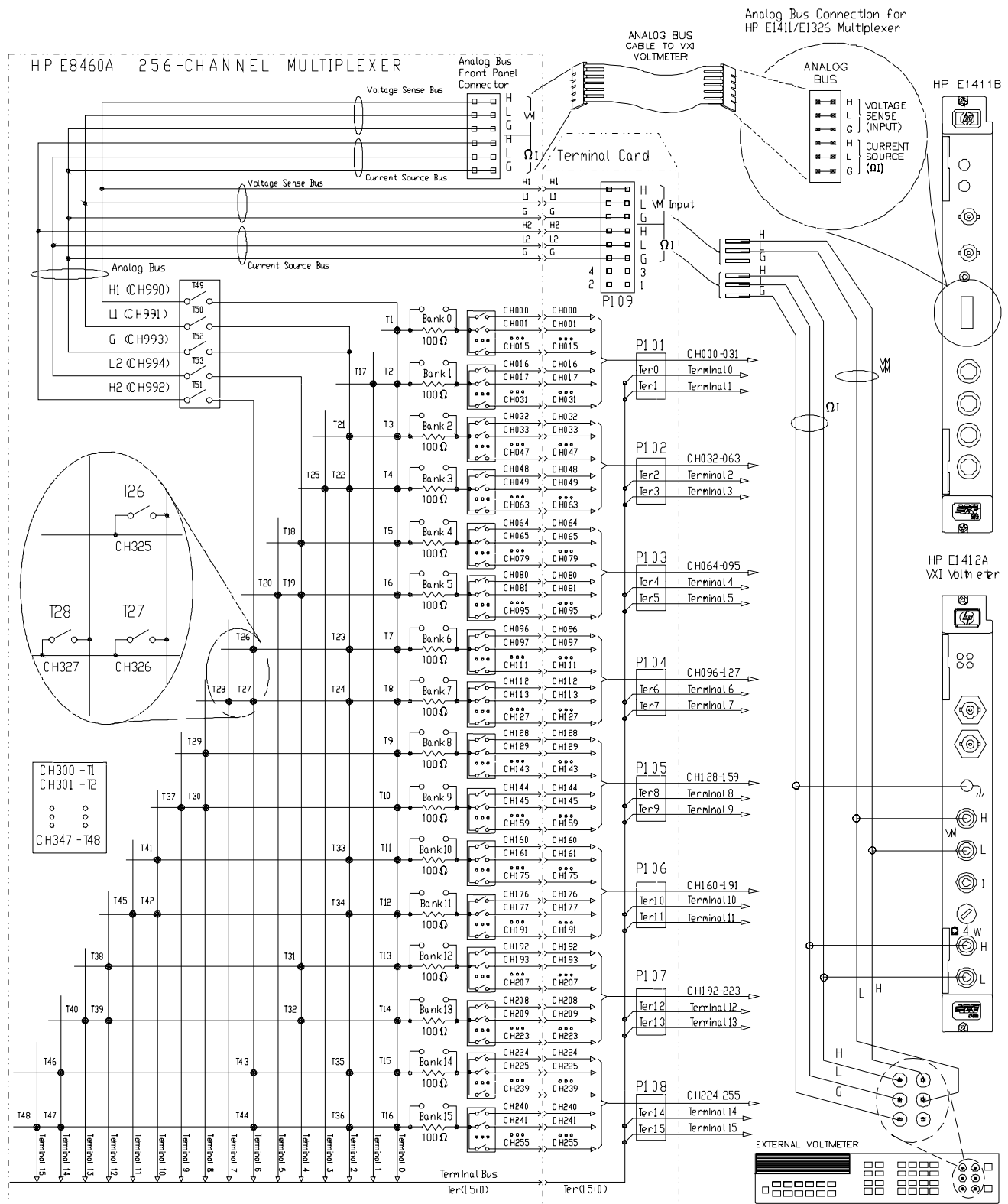

Figure 1-1. HP E8460A Simplified Schematic

Warnings and Cautions



WARNING **SHOCK HAZARD.** Only qualified, service-trained personnel who are aware of the hazards involved should install, configure, or remove the Multiplexer Module. Disconnect all power sources from the mainframe, the Terminal Cards, and installed modules before installing or removing a module.

WARNING When handling user wiring connected to the Terminal Card, consider the highest voltage present accessible on any terminal. Use only wire with an insulation rating greater than the highest voltage which will be present on the Terminal Card. Do not touch any circuit element connected to the Terminal Card if any other connector to the Terminal Card is energized to more than 30VACRMS or 60VDC.

Caution **MAXIMUM VOLTAGE/CURRENT.** Maximum allowable voltage per channel, terminal-to-terminal or terminal-to-chassis for the Multiplexer is 200 VDC, 140 VACrms, or 200VACpeak. Maximum switching current per channel is 500 mA (non-inductive). Maximum transient voltage is 1200V peak. Exceeding any limit may damage the Multiplexer Module.

Caution **WIRING THE TERMINAL CARD.** When wiring to the terminal connectors on the HP E8460A Terminal Card, be sure not to exceed a 5mm strip back of insulation to prevent the possibility of shorting to other wiring on adjacent terminals.

Caution **STATIC ELECTRICITY.** Static electricity is a major cause of component failure. To prevent damage to the electrical components in the Multiplexer, observe anti-static techniques whenever removing, configuring, and installing a module. The Multiplexer is susceptible to static discharges. Do not install the Multiplexer Module without its metal shield attached.

Configuring the Multiplexer Module

The Multiplexer module can be configured to the operating modes through the *VXIplug&play* driver or via SCPI commands. These drivers are located on the supplied CD-ROM. Before installing the module into a VXIbus mainframe (e.g. HP E1401A), you need to set the Multiplexer's logical address.

Setting the Logical Address

The factory default logical address switch setting is 112. Valid addresses are from 1 to 254 for static configuration and address 255 for dynamic configuration. The HP E8460A supports dynamic configuration of the address. This means the address is set programmatically by the resource manager when it encounters a module with address 255.

The logical addresses must be sequential if multiple modules are used to form a switchbox. See Figure 1-13. "Card Numbers in a Multiple-module Configuration" on page 30 for more information.

Refer to the *C-Size VXIbus System Installation and Getting Started Guide* for addressing information. Figure 1-2 shows the logical address switch position.

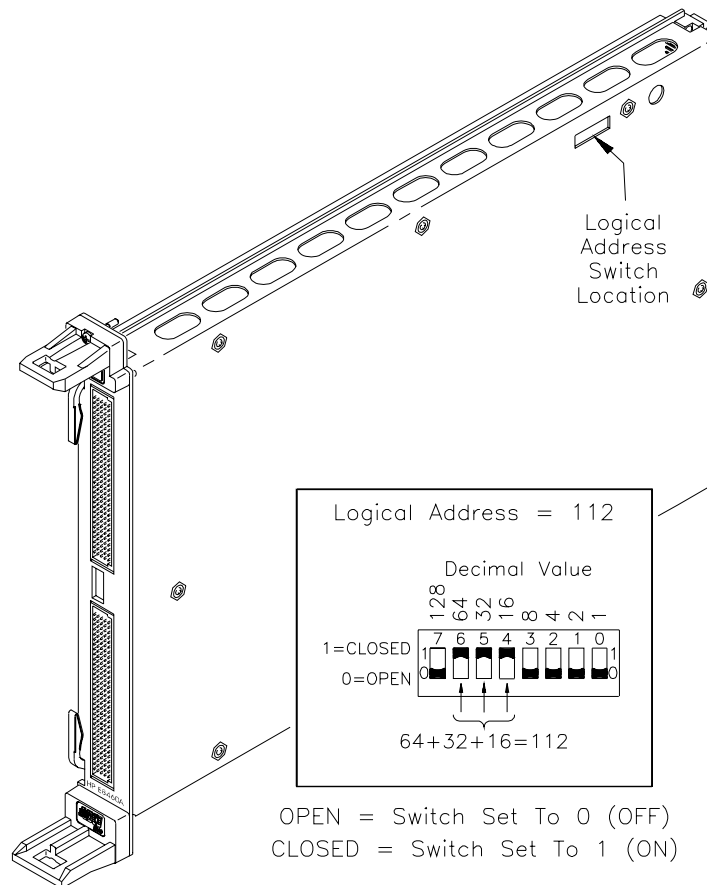

Figure 1-2. Setting the Logical Address

Setting the Interrupt Priority Line

For most applications the default priority line should not have to be changed. An interrupt is generated after any channel is opened or closed when interrupts are enabled. The interrupt is generated approximately 500 μ s after command execution allowing for relay settling time. The interrupt line can be set to any one of the VXI backplane lines 1-7 through writing the bits 10, 9 and 8 of the Status/Control Register. The default value is 1. The interrupt can be disabled at power-up, after a SYSRESET, or after resetting the module via the Control Register.

See *Appendix B, HP E8460A Register-Based Programming* for more information of setting the interrupt priority line by writing to the Status/Control Register.

Protection Resistors

Figure 1-1 shows the 100 Ω protection resistors in series with each bank line. These protection resistors limit the maximum current through the relays. However, in some measurements (such as 2-Wire resistance measurements) you may want to bypass the protection resistors. Each resistor has a jumper (J601 for Bank 0, JP602 for Bank 1, JP 603 for Bank2, . . . JP616 for Bank 15) across it allowing you to short out the resistor if necessary. Refer to Figure 1-3. The default is to have the jumper in the offset position so the resistor is not shorted.

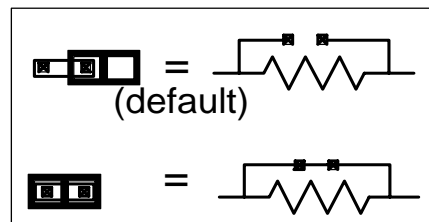

Figure 1-3. Protection Resistors and Jumpers

Installing the Multiplexer in a Mainframe

The HP E8460A may be installed in any slot (except slot 0) in a C-size VXibus mainframe. Refer to Figure 1-4 to install the Multiplexer in a mainframe.

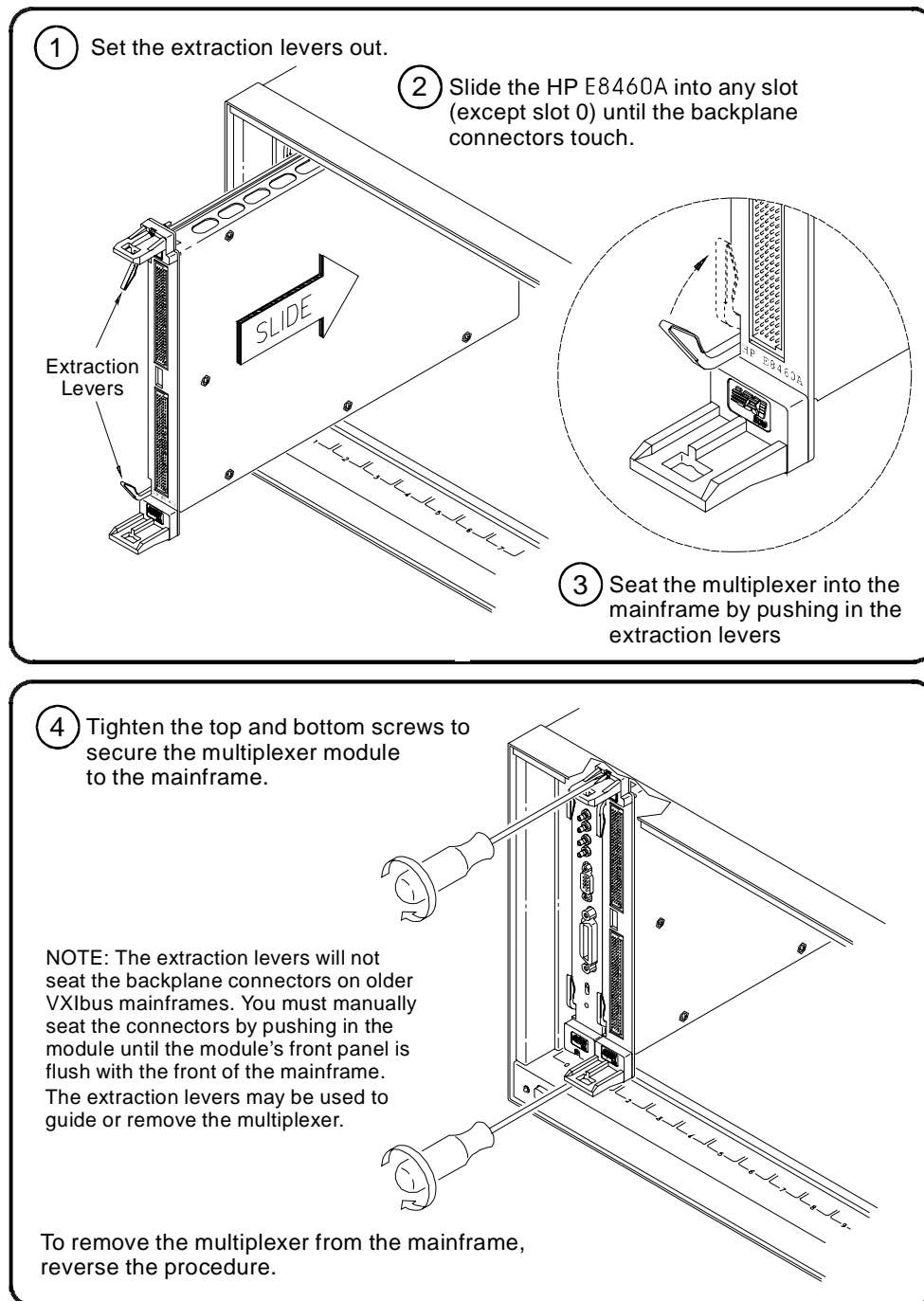

Figure 1-4. Installing the Multiplexer in a VXibus Mainframe

Connecting Field Wiring

As mentioned before, the HP E8460A is not supplied with terminal connector blocks or terminal cards. Figure 1-6 shows the Multiplexer's front panel and the connector pin-out.

Ter0 to Ter15 refer to Terminal 0 through Terminal 15. T_ACCESS* and T_ERROR* are two signals to drive LEDs on the Option 012 Terminal Card. "NC" refers to "Not Connected" and "CGND" refers to "Chassis Ground".

Terminal Connector Blocks

Refer to Figure 1-5. You may purchase 160-pin terminal connector blocks (two are required, order HP part number 1252-6531 or direct from the manufacturer, ERNI part number 024070) and the necessary crimp-and-insert contacts (HP pn for single contact is 1252-6533, or ERNI pn 014728). The contacts are gold-plated, accept a wire size of 20 to 26AWG, and carry a maximum current of 2A @70°C. You will also need a crimp tool (HP pn 8710-2306 or ERNI pn 014374) and optionally a disassembly tool (HP pn 8710-2307 or ERNI pn 471555).

Caution Due to the close terminal spacing and the potential for pin-to-pin leakage, the terminal connector blocks must be replaced after 10,000 hours of use if the module regularly switches voltages greater than 60VDC, 50VACrms, or 70.7 VACpeak.

A single-conductor with contact (a crimp-and-insert contact is crimped onto one end, the other end is not terminated) is available as HP pn 8150-5207.

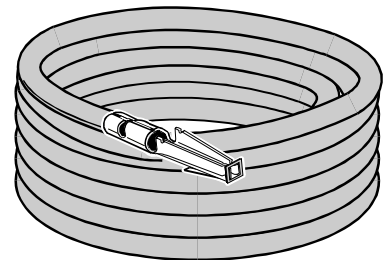
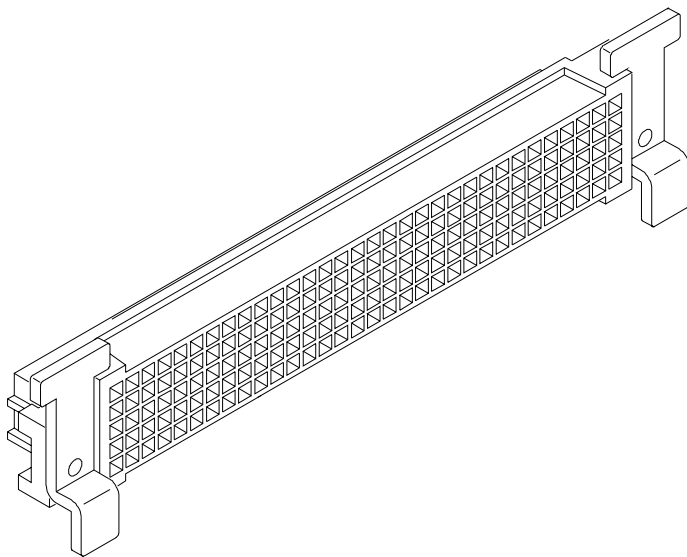

Length: 2 meters
Wire Gauge: 24 AWG
Insulation Rating: 105 C maximum
Voltage: 300 V maximum

Figure 1-5. Terminal Connector Block and Single-Conductor Wire with Contact

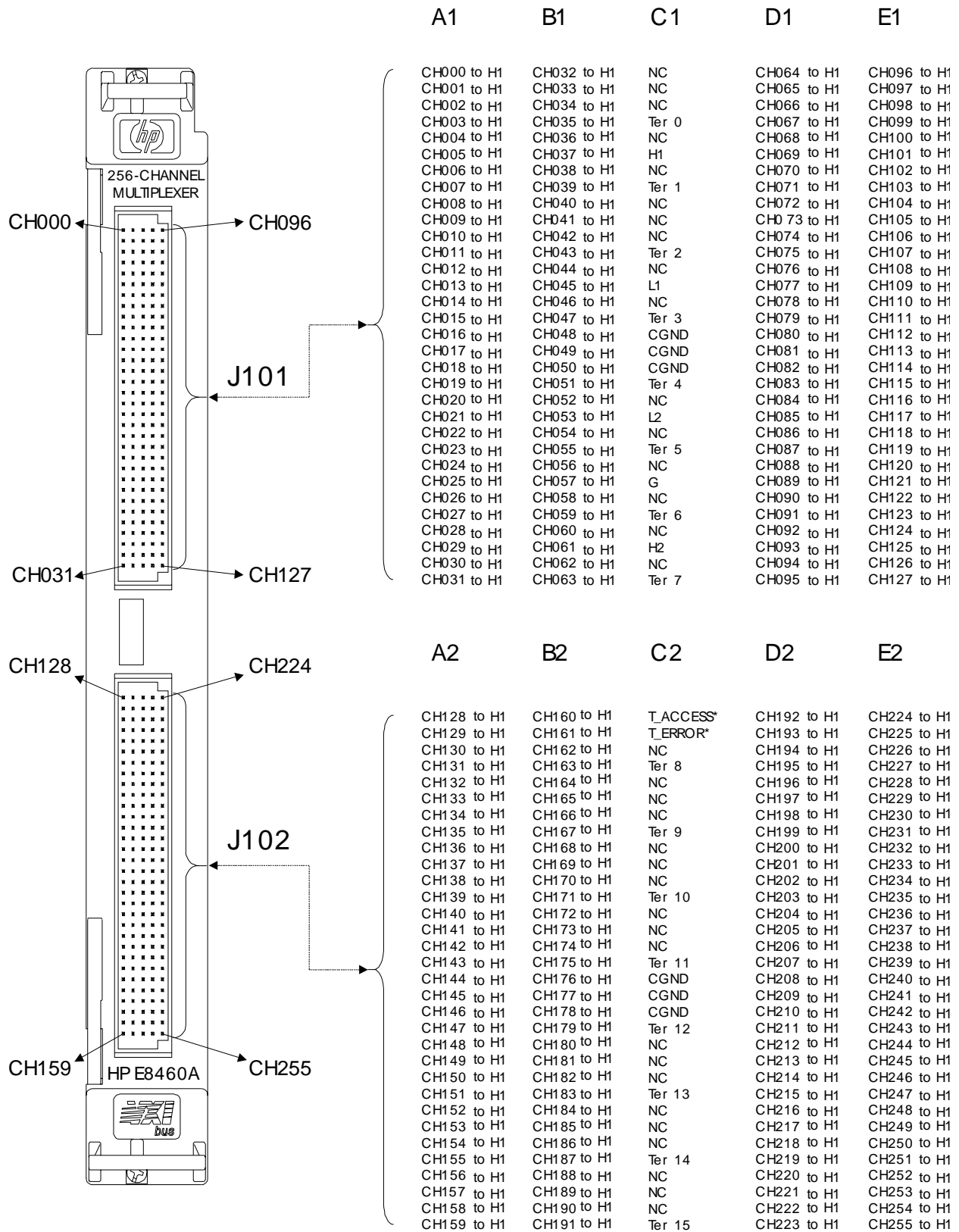

Figure 1-6. HP E8460A Multiplexer Front Panel Pin-out 1-Wire Mode, (Default)

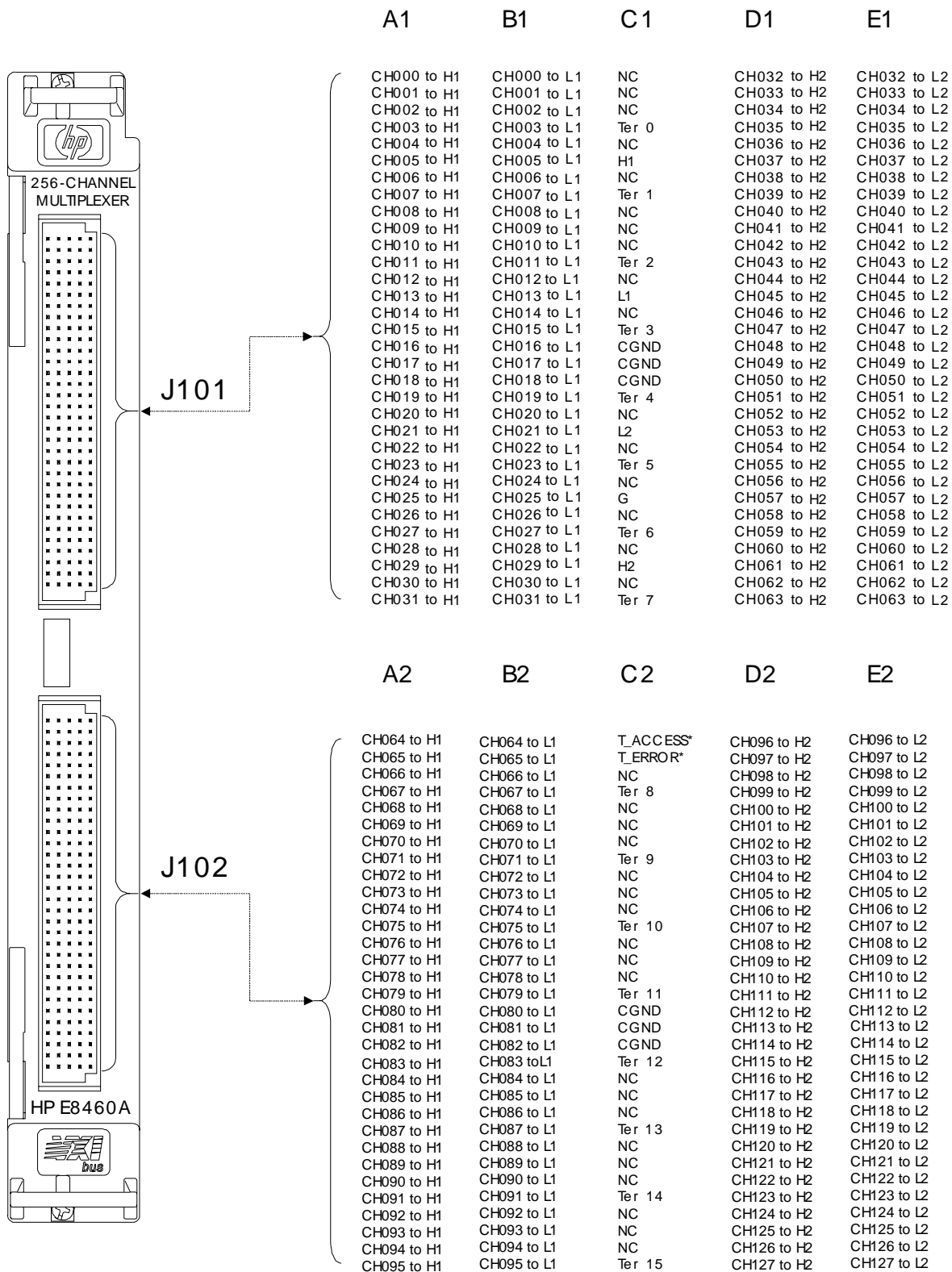

Figure 1-7. HP E8460A Multiplexer Front Panel Pin-out 2-Wire Mode

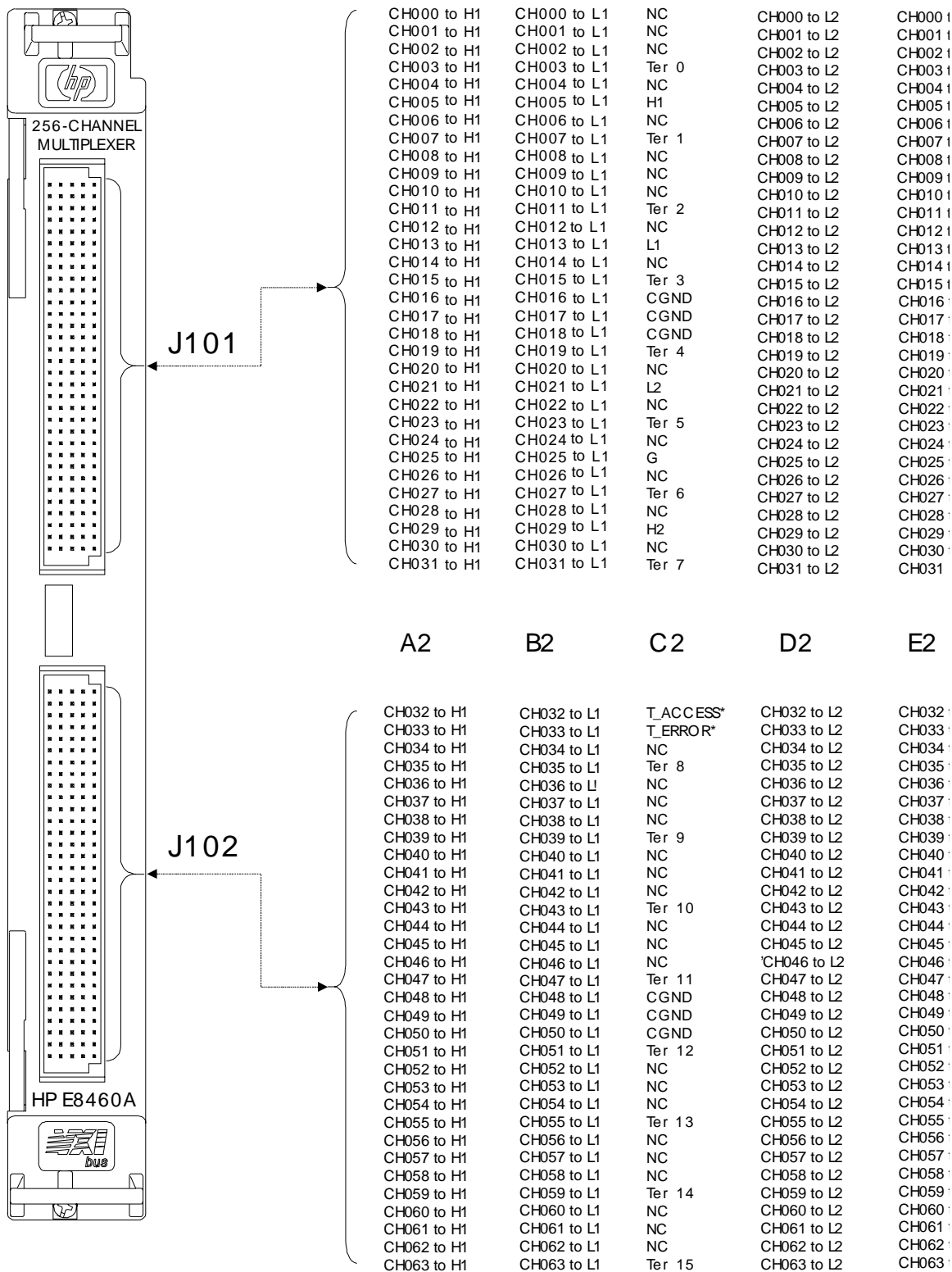

Figure 1-8. HP E8460A Multiplexer Front Panel Pin-out 3- and 4-Wire Mode
(3-Wire Mode does not use Column E connections)

Connecting the Analog Bus

The analog bus provides a common bus to all switch modules in multiple switch cards. A multimeter or other instrument can be connected to the analog bus. Use flat ribbon analog bus cables between Multiplexers and other HP VXI modules that have an analog bus (both C-size modules or B-size modules in a C-size adapter). HP E1411A/B 5-Digit Multimeter users (and HP E1326 in a C-size adapter) must continue the analog bus connection between Multiplexers and switch modules to the multimeter in order to use the scanning and measurement capability the multimeter has to offer. These cables provide the input to the multimeter from the multiplexer/switch channels and fit under the Multiplexer's optional terminal cards. See Figure 1-9.

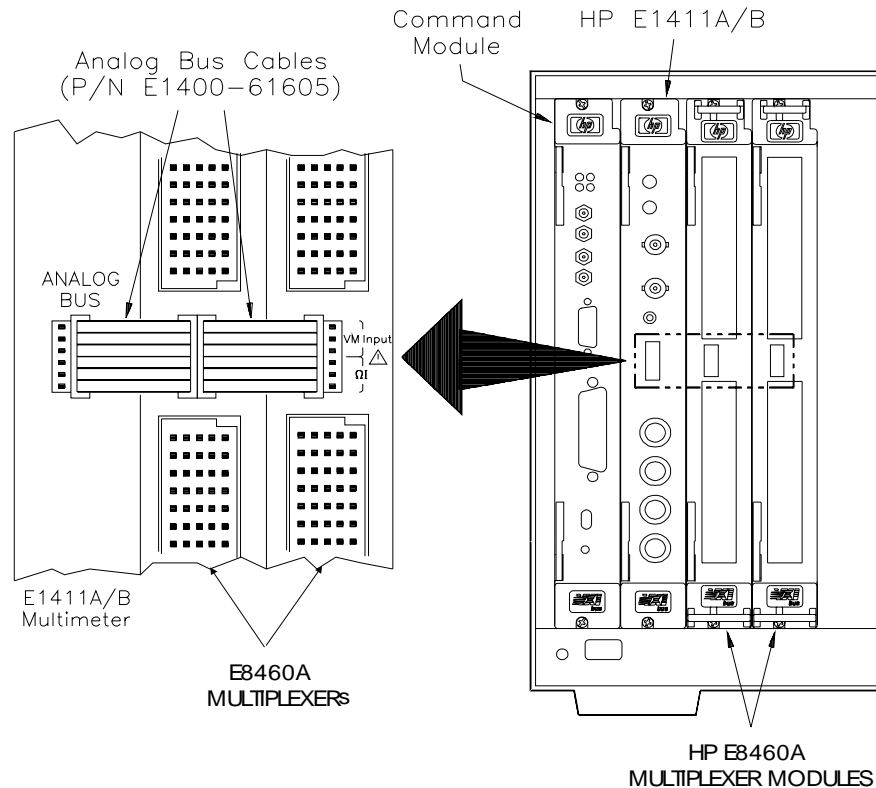

Figure 1-9. HP E1411A/B Connections to the Analog Bus

Note An external measuring device can be connected to the analog bus through the terminal card's terminals (pin 5 through pin 16 of connector P109). See Option 014 Fault Tolerant Terminal Block on page 23.

Note If you are using the HP E1326A/B 5½-Digit Multimeter in a C-size adapter. Use the 19.5 inch analog bus cable part number E1326-61611 for analog bus connection between your HP E1326 and the HP E8460A. The cable described above will be too short for connection to the HP E1326.

WARNING If either end of the analog bus is accessible to users (such as on the front panel of a multimeter), the Multiplexer inputs must be limited to 30VACrms or 60VDC.

Terminal Cards

Three optional terminal cards are available for the HP E8460A:

- Option 012 Crimp and Insert Terminal Card
- Option 014 Fault Tolerant Terminal Card
- Option 015 Ribbon Cable Connector Terminal Card

Option 012 Crimp-and-Insert Terminal Block

The Option 012 Terminal Block provides a terminal card housing and two 160-pin terminal connector blocks (HP P/N 1252-6531) but no contacts.

Note

The contacts for the Option 012 Terminal Block connectors **ARE NOT** provided. You must purchase them in addition to the option. This allows you to purchase only the number of contacts you require for your application.

HP P/N 8150-5207 is available for purchase and is a single-conductor with contact (a crimp-and-insert contact is crimped onto one end, the other end is not terminated). Refer to Page 18, "Figure 1-5. Terminal Connector Block and Single-Conductor Wire with Contact".

The crimp-and-insert contacts you must purchase (HP P/N 1252-6533 for single contact) are gold-plated, accept a wire size of 20 to 26AWG, and carry a maximum current of 2A @70°C. You will also need a crimp tool (HP P/N 8710-2306 or ERNI Components P/N 014374) and optionally a disassembly tool (HP P/N 8710-2307 or ERNI Components P/N 471555).

Caution

Due to the close terminal spacing and the potential for pin-to-pin leakage, the terminal connector blocks on the HP E8460A Option 012 Crimp and Insert Terminal Card must be replaced after 10,000 hours of use if the module regularly switches voltages greater than 60VDC, 50VACrms, or 70.7 VACpeak.

Option 014 Fault Tolerant Terminal Block

Option 014 Terminal Block provides nine ribbon-cable header connectors. P101 through P108 provide the channels and terminal bus connection from the front panel connectors (J101 and J102) of the HP E8462A; P109 is a 16-pin connector for the analog bus connection. DS101 and DS102 are LEDs which provide information as follows. The green LED (DS101) will light as the Multiplexer is accessed by the VXI controller. The yellow LED (DS102) monitors the firmware execution, and will light whenever there is error during DIAG:TEST? or *TST? command execution.

Caution

The Option 014 Fault Tolerant Terminal Card is limited 60VDC or 50 VACrms or 70.7 VACpeak maximum. Do not exceed these voltages.

Figure 1-10 shows the associated channel numbers. RT100 through RT355 are 256 PTC¹ resistors which behave like a resettable fuse and will increase

impedance when excessive current is flowing in the channel. For example, if the contacts of one relay are welded together because it switches a large voltage, the PTC resistors help protect user circuitry on other channels in the same bank when their relays close.

Option 015 Ribbon Cable Connector Terminal Block

Option 015 Terminal Block provides nine ribbon-cable header connectors. P101 through P108 provide the channels and terminal bus connection from the front panel connectors (J101 and J102) of the HP E8462A; P109 is a 16-pin connector for the analog bus connection. DS101 and DS102 are LEDs which provide information as follows. The green LED (DS101) will light as the Multiplexer is accessed by the VXI controller. The yellow LED (DS102) monitors the firmware execution, and will light whenever there is error during DIAG:TEST? or *TST? command execution.

Option 015 is identical to option 014 except the PTC fault tolerant resistors are replaced with shorts. This terminal block only provides a convenient means to connect the field wiring, via ribbon cable, to the multiplexer module.

Caution **The Option 015 Ribbon Cable Connector Terminal Card is limited 60VDC or 50 VACrms or 70.7 VACpeak maximum. Do not exceed these voltages.**

1. PTC: Positive Temperature Coefficient.

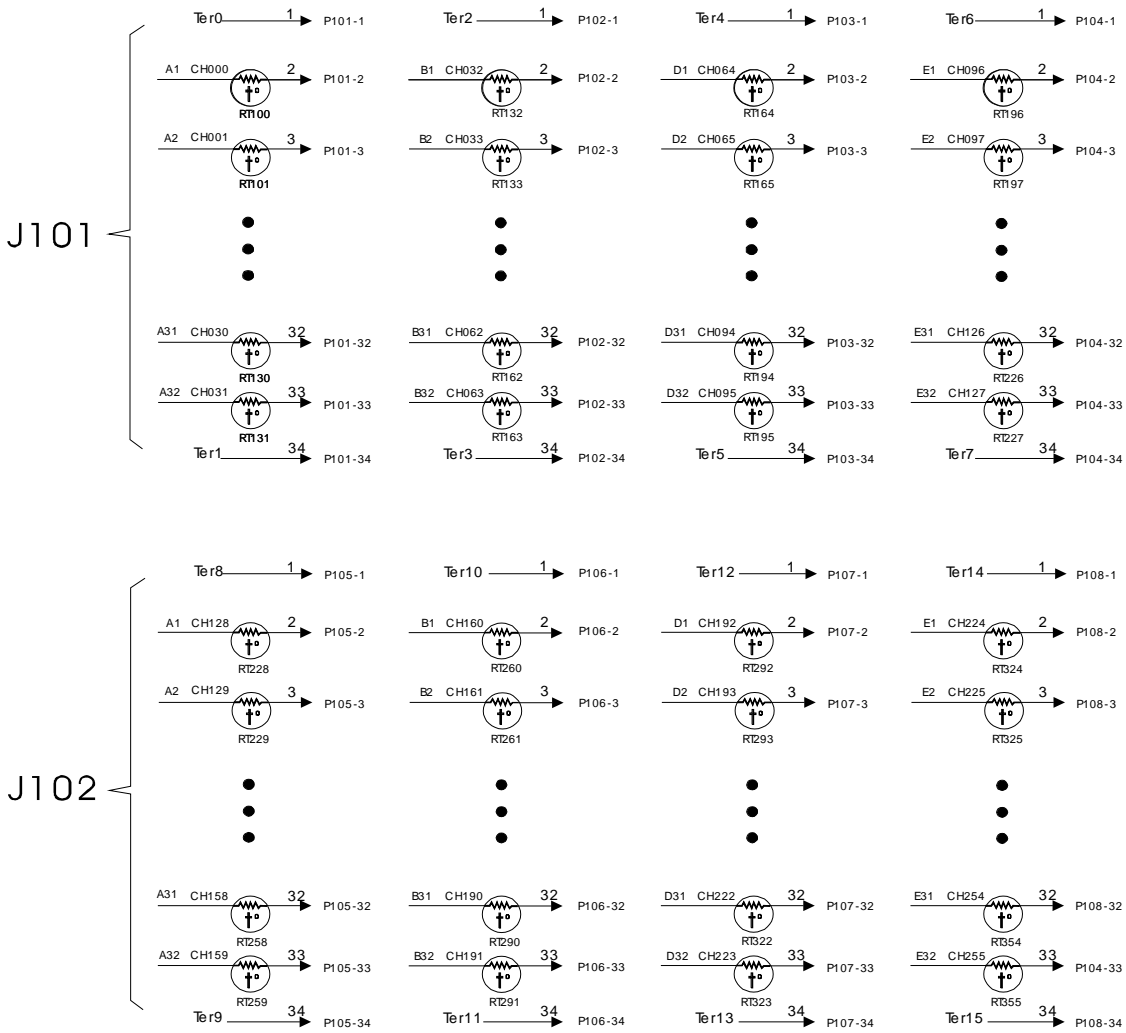
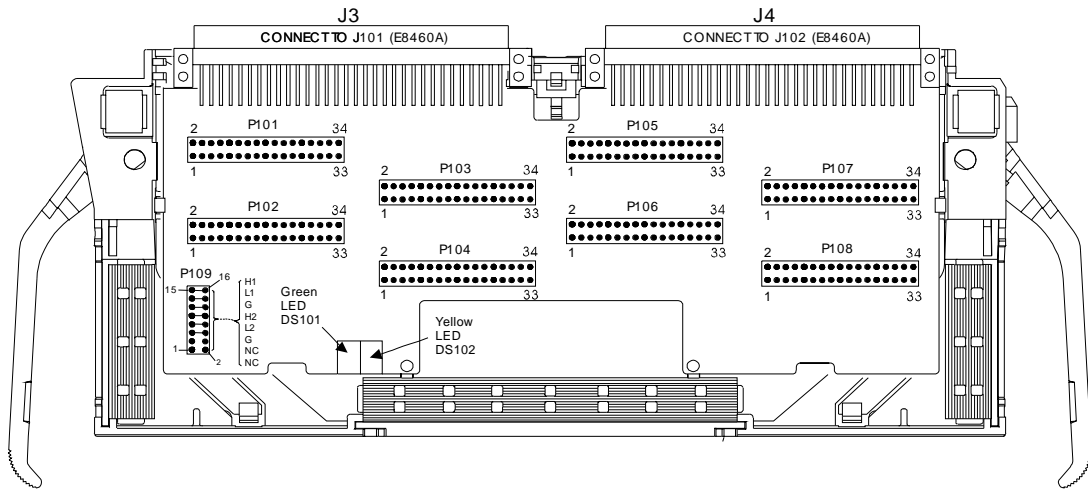

Figure 1-10. HP E8460A Option 014 Fault Tolerant Terminal Card Connectors Pin-out

Wiring a Terminal Card Figure 1-11 shows how to wire the optional terminal cards.

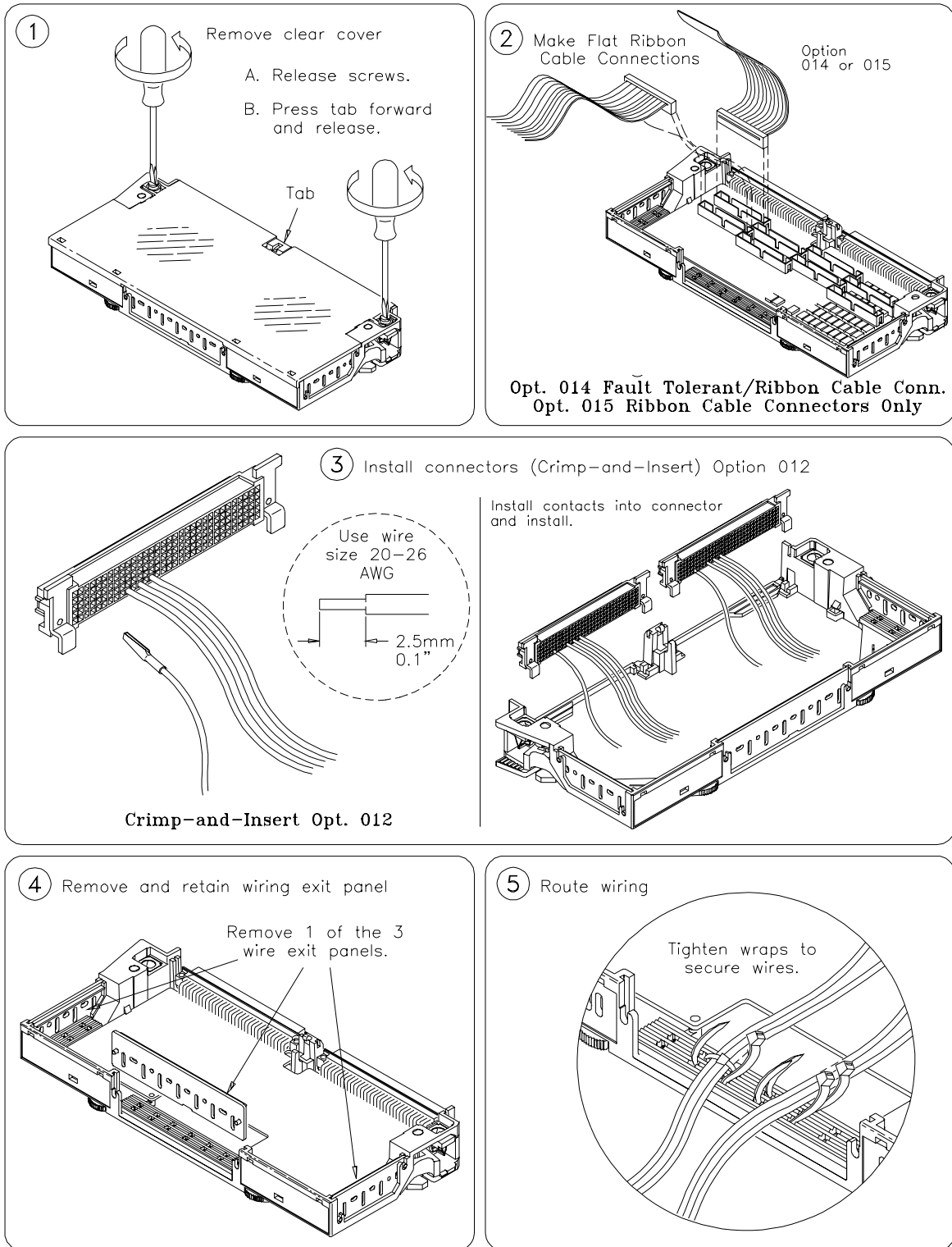

Figure 1-11. Wiring a Terminal Card

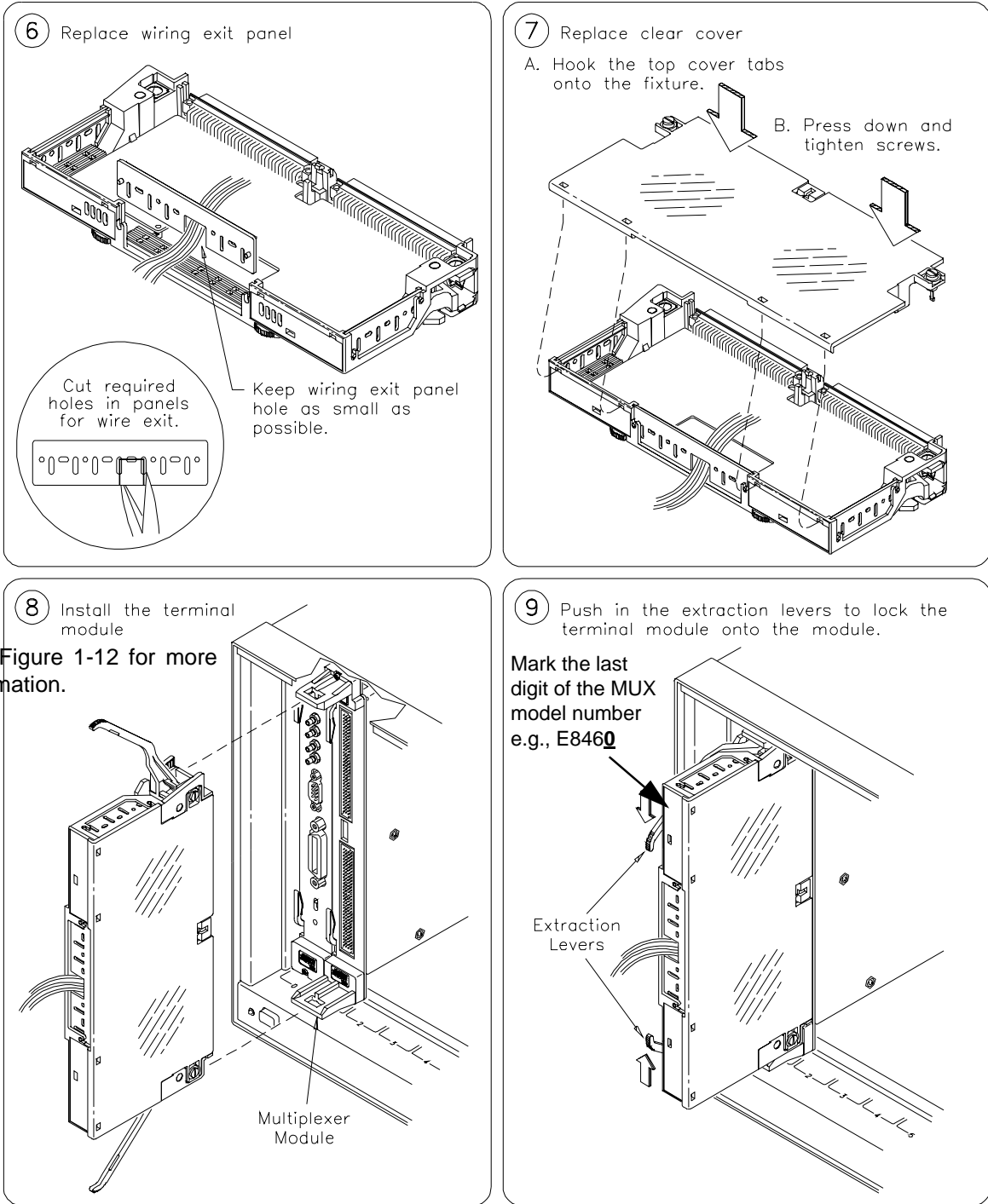

Figure 1-11. Wiring a Terminal Card (continued)

Attaching a Terminal Card to the Multiplexer

Figure 1-12 shows how to attach an optional terminal card to the HP E8460A Relay Multiplexer module.

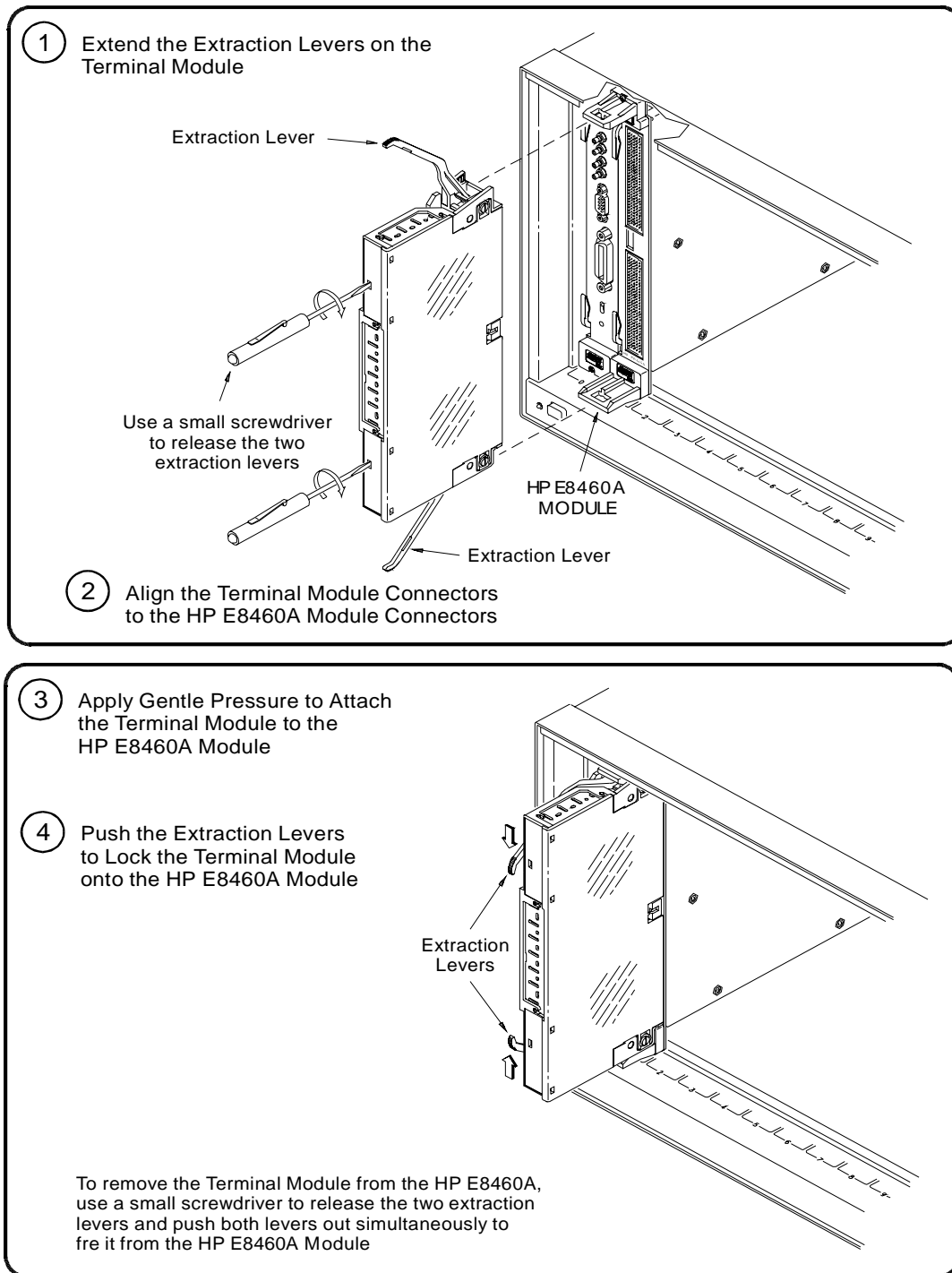

Figure 1-12. Attach a Terminal Card to the Multiplexer

Programming the Multiplexer

To program the HP E8460A Multiplexer using SCPI, you must know the interface and module address and SCPI commands to be used. Guidelines to select SCPI commands for the Multiplexer follow. See the *HP 75000 Series C Installation and Getting Started Guide* for interface addressing.

Note This discussion applies only to SCPI (Standard Commands for Programmable Instruments) programming. See Appendix B for information on the Multiplexer's registers.

Specifying SCPI Commands

To address specific channels within a Multiplexer, you must specify the SCPI command and channel address. Use `CLOSe <channel_list>` to close the channels specified, `OPEN <channel_list>` to open the channels specified, and `SCAN <channel_list>` to close and open the set of channels specified, one channel at a time.

Channel Address

The Multiplexer's channel address (*channel_list*) has the form (@ccnnn) where cc = module (card) number (01-99) and nnn = channel numbers. The channel number consists of three parts listed in the below table:

Channel List	Card Number (cc)	Channel Number (nnn)	Channel Description
ccnnn	01-99	000-255	256 channel relays
		300-347	48 tree relays
		990-994	5 analog bus relays

The tree relays and analog bus relays have the same channel number no matter what operating mode the Multiplexer is. But the channel relays (CH000-255) may have different channel numbers under different operating mode. See the following table:

Operating Mode	Valid Channel Number	Corresponds to 1-Wire Mode Channel
1-wire	000-255	000-255
2-wire	000-127	000-031, 064-095, 128-159, 192-223 (Channel 000 is paired with channel 032, 001 is paired with 033, etc. Channel 064 is paired with 096, 065 with 097, etc. Channel 128 is paired with 160, channel 129 with 161, etc. Channel 192 is paired with 224, channel 193 with 225, etc.)
3-wire	000-063	000-031, 128-159
4-wire	000-063	000-031, 128-159

Refer to Chapter 3 of this Manual, the command [ROUTE:]CLOSE for the paired channel information.

Note You must specify the operating mode BEFORE you execute the commands OPEN, CLOSE, and SCAN. Pay attention to the valid channel numbers when you open, close or scan the specific channel(s) in different operating modes.

The channels can be addressed using channel numbers or channel ranges. You can address the following:

- single channels (@ccnnn);
- multiple channels (@ccnnn,ccnnn,...);
- sequential channels (@ccnnn:ccnnn);
- groups of sequential channels (@ccnnn:ccnnn,ccnnn:ccnnn);
- or any combination of the above.

Card Numbers

The card number (cc of the *channel list*) identifies the module within a multiple switching cards. The card number assigned depends on the switch configuration used. Leading zeroes can be ignored for the module (card) number.

Single-module. In a single Multiplexer module configuration, the card number is always 01 or 1.

Multiple-module. In a multiple-module configuration, modules are set to successive logical addresses. The module with the lowest logical address is always card number 01. The module with the next successive logical address is card number 02, and so on.

Figure 1-13 illustrates the card numbers and logical addresses of a typical multiple-module configuration.

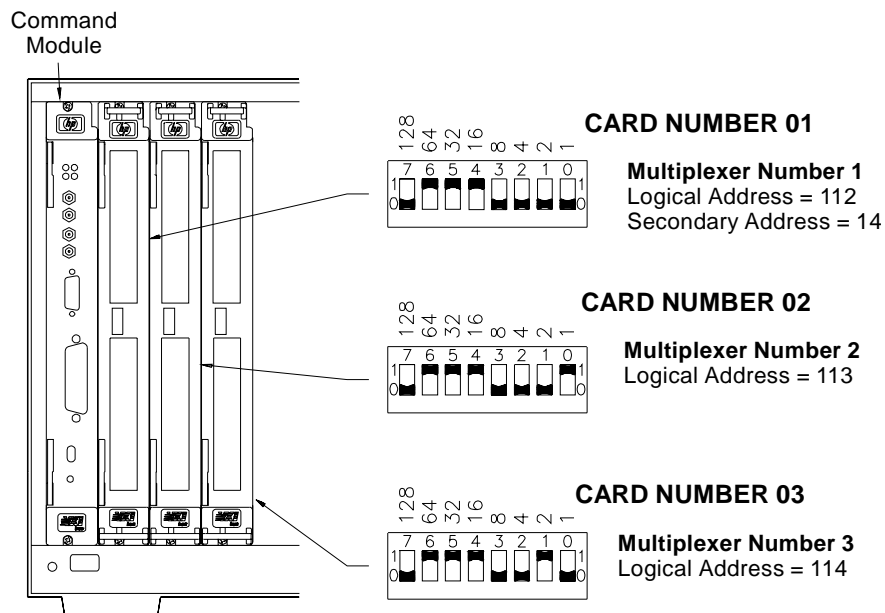

Figure 1-13. Card Numbers in a Multiple-module Configuration

Channel Numbers, Ranges, and Lists

The HP E8460A Multiplexer channel numbers are 000 through 255 under the 1-wire mode. The channels can be addressed using individual channel numbers or channel ranges.

Note

For all other modes, the “channel” is actually used to refer to the paired channel. Under 2-wire mode, there are 128 2-wire paired channels, under 3-wire and 4-wire modes, there are only 64 paired 3-wire or 4-wire channels. See Chapters 2 and 3 for more information of paired channels.

Use commas (,) to form a channel list or use a colon (:) to form a channel range. Only valid channels can be accessed in a channel list or channel range. Also, the channel list or channel range must be from a lower channel number to a higher channel number. For example, CLOS(@1000:1015) is acceptable, but CLOS(@1015:1000) generates an error.

Using the channel range (@nn000:nn999) with the SCAN command causes all channels to be scanned except the tree relays (CH300-347). These are not typical scan channels and therefore are not included in a scan list.

Below are some SCPI commands and a description of their effect on channel lists and ranges.

Channel Lists:

FUNC 1, WIRE2
CLOS(@1000,1001)

*Set the module to 2-wire mode.
Close paired channels 000 and 001 on card #1 (channels 0, 1, 32 & 33 will be closed together).
Open paired channels 03 and 10 on card #1.*

OPEN(@1003,1010)

Channel Ranges:

FUNC 1, WIRE1
OPEN (@1000:1255)
CLOS (@1000,1127)

*Set the module to 1-wire mode.
Open all channels on card #1.
Close channels 000 and 127 on card #1.*

SCAN (@1128:1255)

Define channels 128-255 to be scanned.

Initial Operation

You must download the HP E8460A SCPI driver into the HP E1405/E1406 Command Module to perform the initial operation.

At power-on or following a reset of the module (*RST command), all 256 channels are open. A *RST command invalidates the current scan list (that is, you must specify a new scan list). Command parameters are set to the default conditions as shown below.

Parameter	Default Value	Description
ARM:COUNT	1	Number of scanning cycles is one.
TRIGger:SOURce	IMM	Advances through a scanning list automatically.
INITiate:CONTinuous	OFF.	Continuous scanning disabled.
OUTPut[:STATe]	OFF	Trigger output from EXT, TTL, or ECL sources is disabled.
[ROUte:]FUNC	NONE	Operating mode is set to NONE. You must always set the mode after power-on or reset the module.
[ROUte:]SCAN:MODE	NONE	Channel list is not set up.
[ROUte:]SCAN:PORT	NONE	Analog bus connections are disabled from channels.

Execute SCAN:PORT ABUS to enable use of the analog bus for the SCAN command. A CLOSe command requires that you also close the appropriate tree relay to make connection to the analog bus (see Page 13 "Figure 1-1. HP E8460A Simplified Schematic").

Note Do not do register writes if you are controlling the module by a high level driver such as SCPI or *VXIplug&play*. This is because the driver will not know the module state and an interrupt may occur causing the driver and/or command module to fail.

The following example program was developed with the ANSI C language using the HP VISA extensions. The program was written and tested in Microsoft® Visual C++ but should compile under any standard ANSI C compiler.

To run the program you must have the HP SICL Library, the HP VISA extensions, and an HP 82340 or 82341 HP-IB module installed and properly configured in your PC. An HP E1406 Command Module is required.

Example: Reset, Self Test, Module ID, and Close Channel

The following example reads the module ID string, performs module self-test, displays the results, closes channel 002 and queries the channel closure state. The result is returned to the computer and displayed (“1” = channel closed, “0” = channel open).

```
#include <visa.h>
#include <stdio.h>
#include <stdlib.h>

/* Module Logical address is 112, secondary address is 14*/
#define INSTR_ADDR "GPIB0::9::14::INSTR"

int main()
{
    ViStatus errStatus; /*Status from each VISA call*/
    ViSession viRM; /*Resource mgr. session */
    ViSession E8460A; /* Module session */
    char id_string[256]; /*ID string*/
    char selftst_string[256]; /*self-test string*/
    char ch_state; /*channel open/close state*/

    /* Open the default resource manager */
    errStatus = viOpenDefaultRM ( &viRM);
    if(VI_SUCCESS > errStatus){
        printf("ERROR: viOpenDefaultRM() returned 0x%x\n",errStatus);
        return errStatus;}

    /* Open the Module instrument session */
    errStatus = viOpen(viRM,INSTR_ADDR, VI_NULL,VI_NULL,&E8460A);
    if(VI_SUCCESS > errStatus){
        printf("ERROR: viOpen() returned 0x%x\n",errStatus);
        return errStatus;}

    /* Reset the Module */
    errStatus = viPrintf(E8460A, "**RST;*CLS\n");
    if(VI_SUCCESS > errStatus){
        printf("ERROR: viPrintf() returned 0x%x\n",errStatus);
        return errStatus;}

    /* Perform Module Self-Test */
    errStatus = viQueryf(E8460A,"DIAG:TEST?\n","%t",selftst_string);
    if (VI_SUCCESS > errStatus) {
        printf("ERROR: viQueryf() returned 0x%x\n",errStatus);
        return errStatus;}
    printf("Self Test Result is %s\n",selftst_string);

    /* Query the Module ID string */
    errStatus = viQueryf(E8460A,"*IDN?\n","%t",id_string);
    if (VI_SUCCESS > errStatus) {
        printf("ERROR: viQueryf() returned 0x%x\n",errStatus);
        return errStatus;}
    printf("ID is %s\n",id_string);
}
```

```

    /* Close Channel 002 */
errStatus = viPrintf(E8460A, "FUNC 1,WIRE1;CLOS (@1002)\n");
if(VI_SUCCESS > errStatus){
    printf("ERROR: viPrintf() returned 0x%x\n",errStatus);
    return errStatus;}

    /* Query State of Channel 002 */
errStatus = viQueryf(E8460A,"ROUT:CLOS? (@1002)\n","%t",ch_state);
if (VI_SUCCESS > errStatus) {
    printf("ERROR: viQueryf() returned 0x%x\n",errStatus);
    return errStatus;}
printf("Channel State is: %s\n",ch_state);

    /* Open Channel 002 */
errStatus = viPrintf(E8460A, "OPEN (@1002)\n");
if(VI_SUCCESS > errStatus){
    printf("ERROR: viPrintf() returned 0x%x\n",errStatus);
    return errStatus;}

    /* Close the Module Instrument Session */
errStatus = viClose (E8460A);
if (VI_SUCCESS > errStatus) {
    printf("ERROR: viClose() returned 0x%x\n",errStatus);
    return 0;}

    /* Close the Resource Manager Session */
errStatus = viClose (viRM);
if (VI_SUCCESS > errStatus) {
    printf("ERROR: viClose() returned 0x%x\n",errStatus);
    return 0;}

return VI_SUCCESS;
}

```

What's in This Chapter

This chapter shows how to use the HP E8460A 256-Channel Multiplexer module. The chapter contains the following sections:

- Reset Conditions Page 35
- Switching or Scanning Page 36
- Scanning Channels Using the Analog Bus Page 43
- Recalling and Saving States Page 53
- Detecting Error Conditions Page 54

Reset Conditions

At power-on or following the reset of the module (*RST command), all 256 channel relays, 48 tree relays, and five analog bus connection relays are open. In addition, after a *RST command, the scan channel list is empty. Table 2-1 lists the parameters and default values for the functions following turn-on or reset.

Table 2-1. HP E8460A Default Conditions for Power-on and Reset

Parameter	Default Value	Description
ARM:COUNT	1	Number of scanning cycles is one.
TRIGger:SOURce	IMM	Advances through a scanning list automatically.
INITiate:CONTinuous	OFF	Continuous scanning disabled.
OUTPut[:STATe]	OFF	Trigger output from EXT, TTL, or ECL sources is disabled.
[ROUTe:]SCAN:MODE	NONE	Channel list is not set up.
[ROUTe:]SCAN:PORT	NONE	Analog bus connections are disabled.
Channel state	All 256 channels are open (CH000-255 are open).	
Tree relays state	All 21 tree relays are open (CH9000-9021).	
Routing relays state	All routing relays are normally closed (CH9100-9108).	
Analog bus connection relay status	5 analog bus relays are open (CH9200-9204).	
Channel list from SCAN command (after *RST)	Channel list is empty following a reset of the module with *RST command.	

Switching or Scanning

There are two general ways to use the HP E8460A Relay Multiplexer. First, you can use the ROUTe:FUNCTION command subsystem (see Chapter 3) to set up the multiplexer in any of its four operating modes: 1-Wire, 2-Wire, 3-Wire, or 4-Wire Mode. You can then use the ROUTe:CLOSe or ROUTe:OPeN commands to control individual channel relays. In the 2-Wire, 3-Wire, and 4-Wire modes, banks of channels are paired together such that when you close one channel the paired relay(s) also close automatically. The ROUTe command subsystem automatically closes the appropriate tree relays depending on the multiplexer mode.

Alternately, you can set the multiplexer mode and scan through a list of channels. Scanning involves sequentially closing/opening channels in a channel list. Use the ROUTe:SCAN command to set the scan mode, use the analog bus, and specify the channel in the channel list.

The channel list used in the ROUTe command subsystem includes the 256 channel relays (CH000-255). Valid channel numbers depend on the specified mode. The 48 tree relays (CH300-347), and 5 analog bus connection control relays (CH990-994) are automatically set depending on the specified mode.

Note You must specify the Multiplexer's operating mode before executing the ROUTe:CLOSe, OPeN, or SCAN functions. These three commands **CANNOT** open/close the tree relays (CH300-347). The tree relays can be only configured either by [ROUTe:]FUNCTION or by command DIAGnostic:CLOSe. See Chapter 3 for more details. Also, Figure 1-6, Figure 1-7, and Figure 1-8 shows the valid channel and front panel connections for the various modes.

Note Pay special attention to the valid channel numbers when you execute these SCPI commands. Refer to the comments of the ROUTe subsystem commands in Chapter 3 for more information of the **paired channel** and **valid channel numbers**.

Switching Channels to the Analog Bus

Measurements can be done through either the analog bus or the terminal bus (Ter0-Ter15). When the multiplexer mode is specified, the appropriate tree relays are automatically closed connecting banks to the appropriate terminal bus. To use the analog bus, however, you must execute the ROUTe:SCAN:PORT command. Once closed, tree relays remain closed until specifically opened (DIAG:OPeN command, power removed from the module, or module reset with a *RST command).

Performing Measurements via Analog Bus

To perform measurements via analog bus, you need to either manually close the analog bus connection control relays (CH990-994) through command ROUTe:CLOSe or execute the command ROUTe:SCAN:PORT ABUS.

1-wire, 2-wire, 3-wire and 4-wire measurements can be done via analog bus by connecting CH990-994. These modes are described in more detail later in this chapter.

1-Wire Mode: All the 256 channel relays are connected to Ter0 and connected to analog bus H1 through closing T49 (CH990). Valid channel numbers are 000 through 255.

2-Wire Mode: The 256 channel relays form 128 2-wire pairs which are connected to Ter0 and Ter2 Terminal buses. Through closing T49 and T50 (CH990-991), the specific channel pair is connected to analog bus H1 and L1 to perform 2-wire measurements such as voltage, current and 2-wire resistance measurements. Valid channel numbers are 000 through 127. From the perspective of the 1-Wire mode, channel 000 becomes channel 000 Hi, channel 032 becomes channel 000 LO, etc. Refer to Figure 1-7.

3-Wire Mode: The 256 channel relays form 64 3-wire pairs which connect to H1, L1 and L2 through closing T49, T50, and T53 (CH990, 991 and 994) respectively. The 64 3-wire pairs are: Banks 0/2/4, 1/3/5, 8/10/12 and 9/11/13. Banks 6, 7, 14, 15 are not used. Valid channel numbers are 000 through 063. From the perspective of the 1-wire mode, channel 000 becomes channel 000 HI, channel 032 becomes channel 000 LO1, and channel 064 becomes channel 000 LO2.

4-Wire Mode: The 256 channel relays form 64 4-wire pairs which connect to H1, L1, H2, and L2 by closing T49, T50, T51, and T53 (CH990, 991, 992, 994). In this mode the 4-wire pairs are: Banks 0/2/4/6, 1/3/5/7, 8/10/12/14 and 9/11/13/15. Valid channel numbers are 000 through 063. From the perspective of the 1-wire mode, channel 000 becomes channel 000 HI1, channel 032 becomes channel 000 LO1, channel 064 becomes channel 000 LO2, and channel 096 becomes channel 000 HI2.

Refer to "Figure 2-1. Channel Switching to the Analog Bus" on page 38. It shows the connections of the related tree relays in the 4-wire mode. The analog bus connection control relays are closed to connect specific 4-wire pairs to analog bus H1, L1, H2, and L2. In this mode the 4-wire pairs are: Banks 0/2/4/6, 1/3/5/7, 8/10/12/14 and 9/11/13/15. The valid channel numbers that can be closed/opened/scanned are 000 through 63.

Refer to Chapter 3, ROUTe command subsystem for more information on valid channel numbers and paired channels under different operating modes.

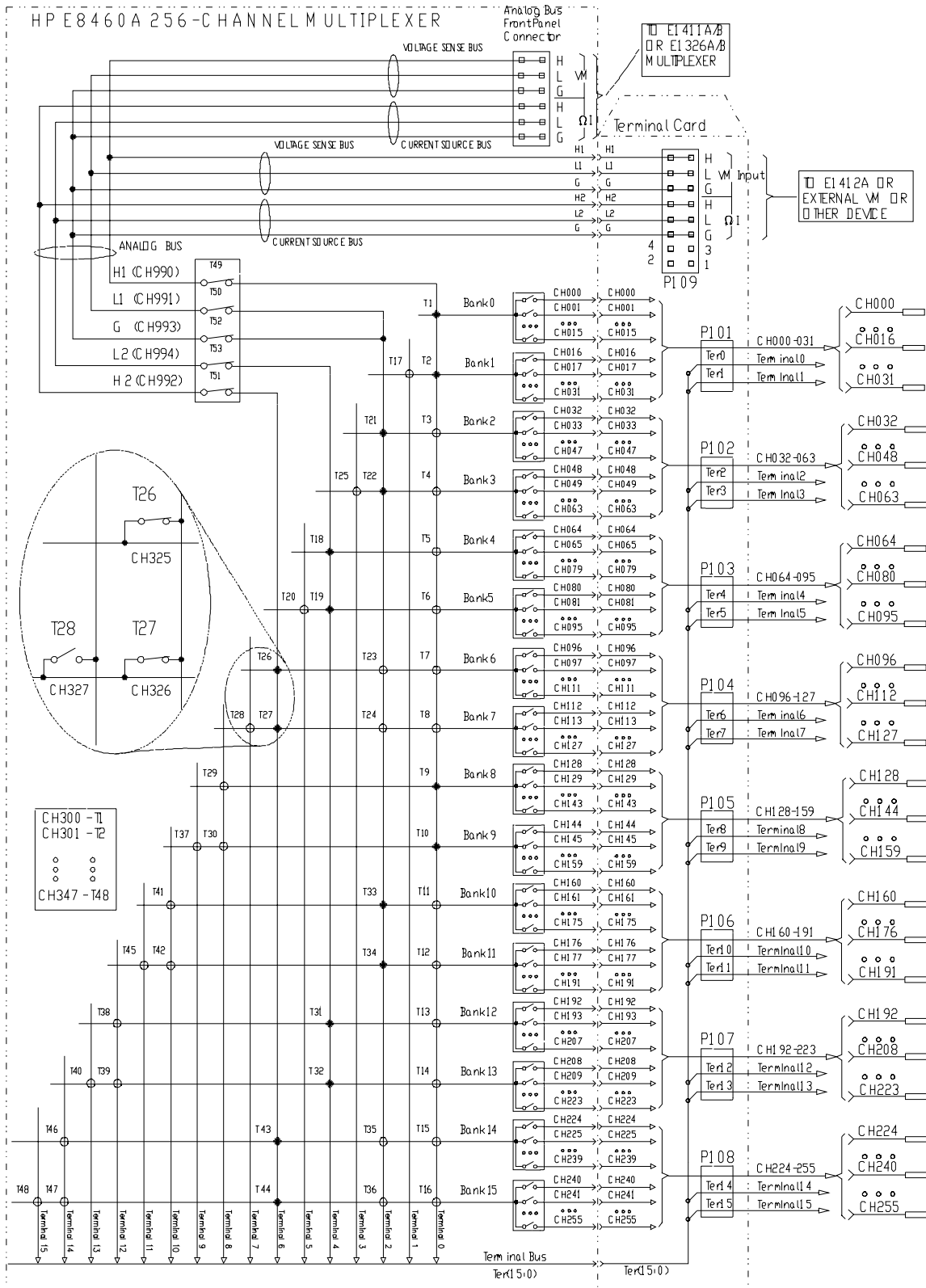

Figure 2-1. Channel Switching to the Analog Bus

1-Wire Mode

In its 1-Wire mode, the HP E8460A is configured as a 1 x 256 multiplexer. In this mode, T1 through T16 are closed to connect the specific channels to Terminal Bus Ter0. The valid channel list to be opened/closed/scanned includes all 256 channels (000-255). All the channels can be also connected to H1 by closing T49 (CH990). Figure 2-2 shows 1-Wire operating mode. The following SCPI command example demonstrates how to set the mode and close a channel.

```
FUNC 1, WIRE1
CLOS (@1005)
```

*Specify the 1-Wire mode.
Close channel 5.*

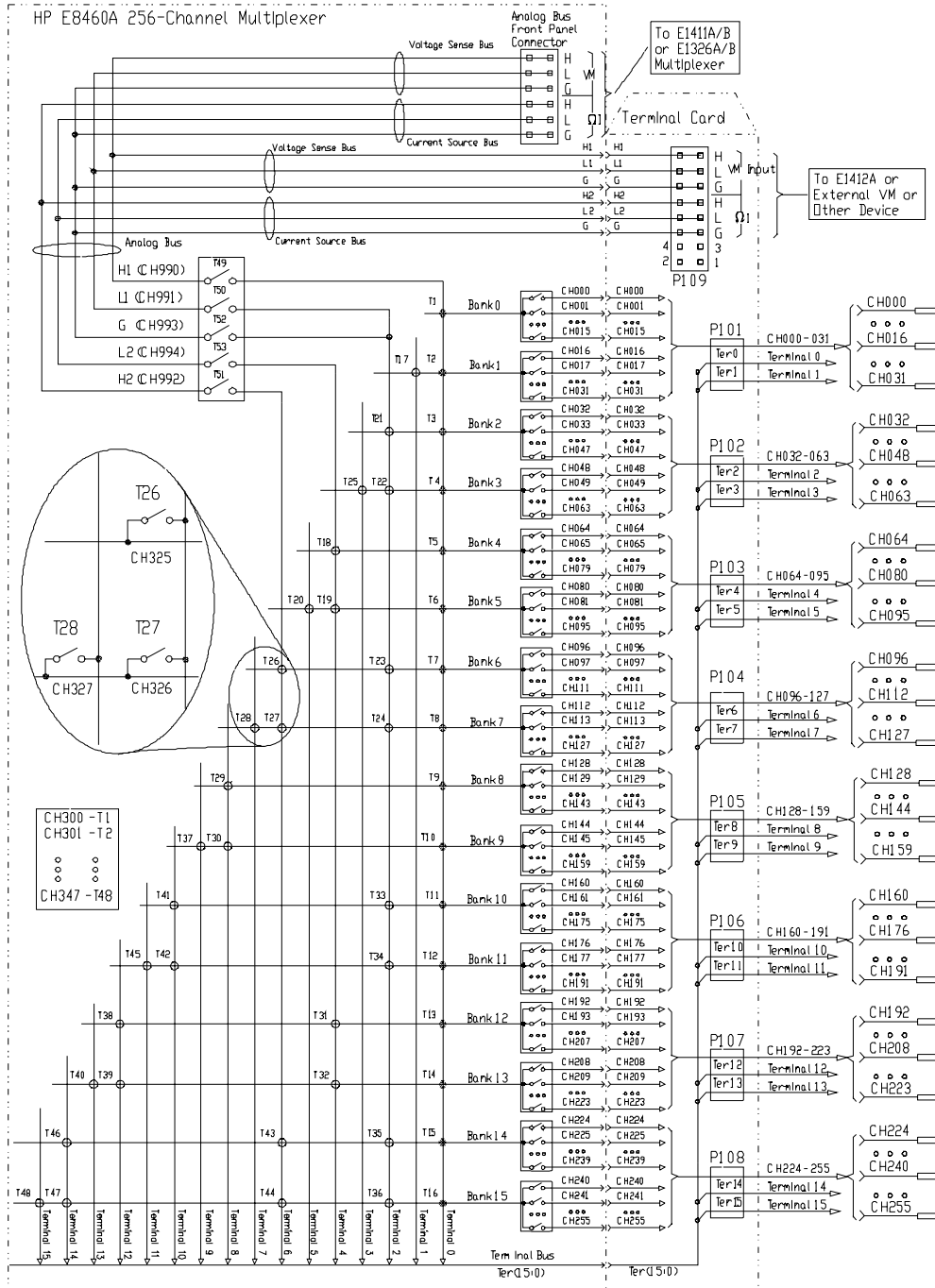

Figure 2-2. 1-Wire (1 x 256 Multiplexer) Operating Mode

2-Wire Mode

Refer to Figure 2-3. In the 2-Wire mode, all 256 channels form 128 2-wire pairs which connect to Terminal Bus Ter0 and Ter2. The valid channel numbers are 000-127. The 128 2-wire pairs are: Banks 0/2, 1/3, 4/6, 5/7, 8/10, 9/11, 12/14 and 13/15. You can also make the 2-wire measurement via the analog bus (H1 and L1), where you must close the tree relays T49 and T50 (CH990, 991). The following example shows how to make 2-wire measurement with a paired channel (CH000 and CH032).

FUNC 1, WIRE2
CLOS (@1000)

*Specify 2-wire Mode.
Close paired Ch000 and Ch032*

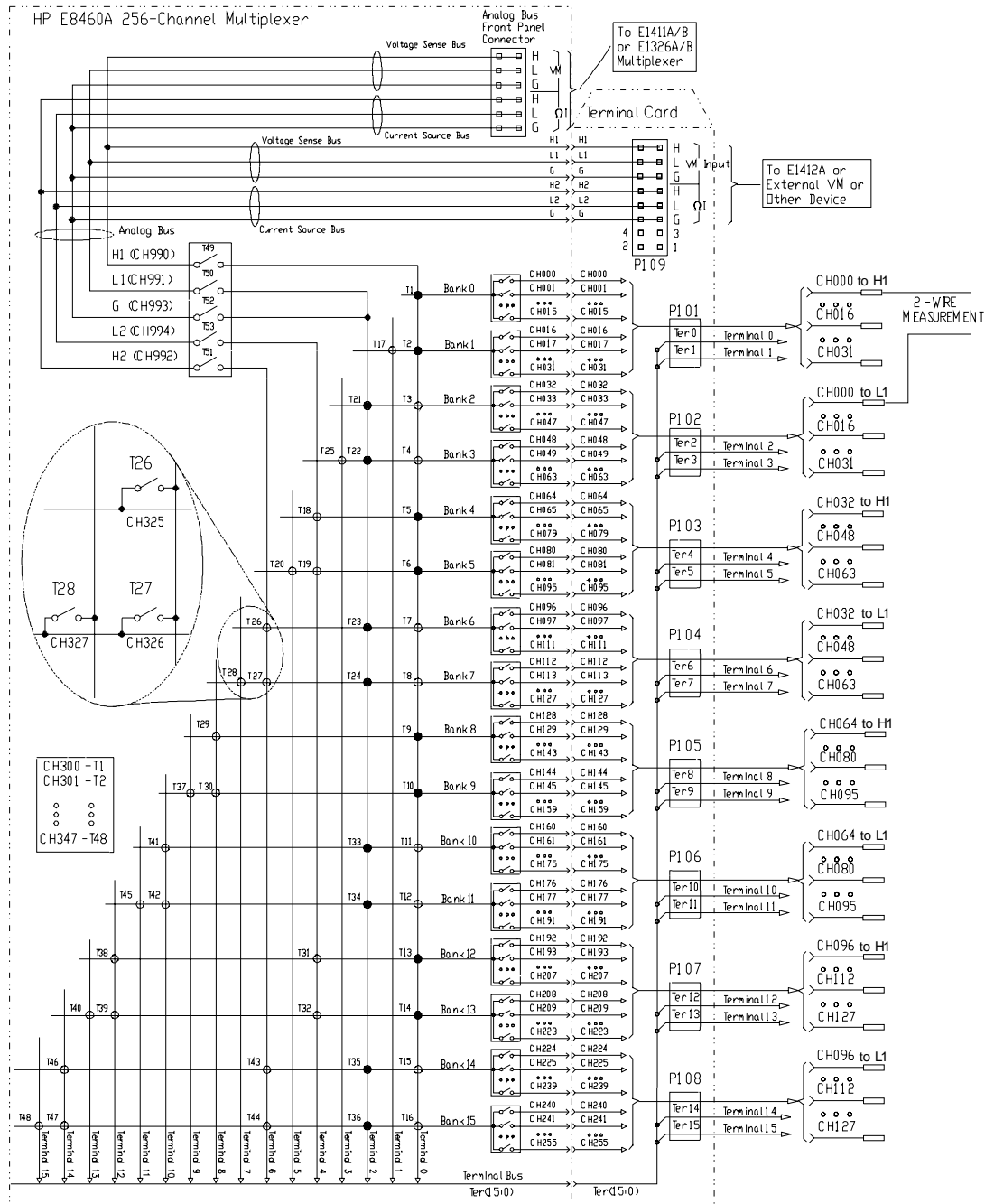

Figure 2-3. 2-Wire Operating Mode

3-Wire and 4-Wire Modes

The same basic configuration is used for both the 3-Wire and the 4-Wire modes. Refer to Figure 2-4. In the 3-Wire mode, relays 0-31 and 128-159 switch to terminal bus Ter0, relays 32-63 and 160-191 switch to Ter2, and relays 64-95 and 192-223 switch to Ter4. In the 4-Wire mode, relays 0-31 and 128-159 switch to terminal bus Ter0, relays 32-63 and 160-191 switch to Ter2, relays 64-95 and 192-223 switch to Ter4 and relays 96-127 and 224-255 switch to Ter6.

In either mode the 256 channels will form 64 wire pairs. The valid channel numbers are 000 through 63. Measurements can be done either through the four terminal bus Terminals 0, 2, 4, and 6 or through the analog bus by closing the analog bus relays T49, T50, T51, and T53 (CH990, 991, 992, 994).

For 4-Wire measurements, you would typically use a pair of channels from banks 0 and 2 for the voltage sense and another pair of channels from banks 4 and 6 for the current source, these four channels forms one 4-wire pair. Closing any channel in the pair automatically closes the other channel in the pair. The following SCPI example shows how to set the 4-Wire mode and how to close the paired channels.

```
FUNC 1, WIRE4  
CLOS (@1000)
```

*Configure 4-wire mode.
Close channel 000. Channels
032, 064, 096 are 4-wire pair
and will close automatically.*

Other Modes

The HP E8460A can also be configured as eight 32X1 multiplexers or sixteen 16X1 multiplexers. There are no commands to automatically set these modes; if you want to configure the sixteen 16x1 multiplexers, you must use the DIAG:CLOSE and DIAG:OPEN command to set the appropriate tree relays.

Caution

When executing DIAGnostic:CLOSE, the specified channel(s) will close without any checking by the firmware. To prevent unexpected short circuits or other undesirable results, be very careful when specifying which channel is to be closed.

Maximum Relay Closures

Using the DIAG:CLOSE command, it is possible to exceed the maximum specified current draw of the module. If all 309 relays are closed (at 10mA per relay) plus the additional current draw from the digital logic circuits; the maximum possible current draw is 3.2 Amps from the +5 VDC supply. The module specification (refer to Appendix A) is for one-half of the relays closed resulting in a 1.7A current draw.

To limit the number of relays closing at any instant, the driver will limit the number of relay closures to 36, limiting the dynamic current draw to 360 mA (specification is 400 mA). If you specify more than 36 channels in the DIAG:CLOSE command, the driver will close the first 36, wait 0.5mS for closure to complete, close the next 36 channels, wait 0.5mS, close the next

36 channels, wait 0.5 mS, and so on.

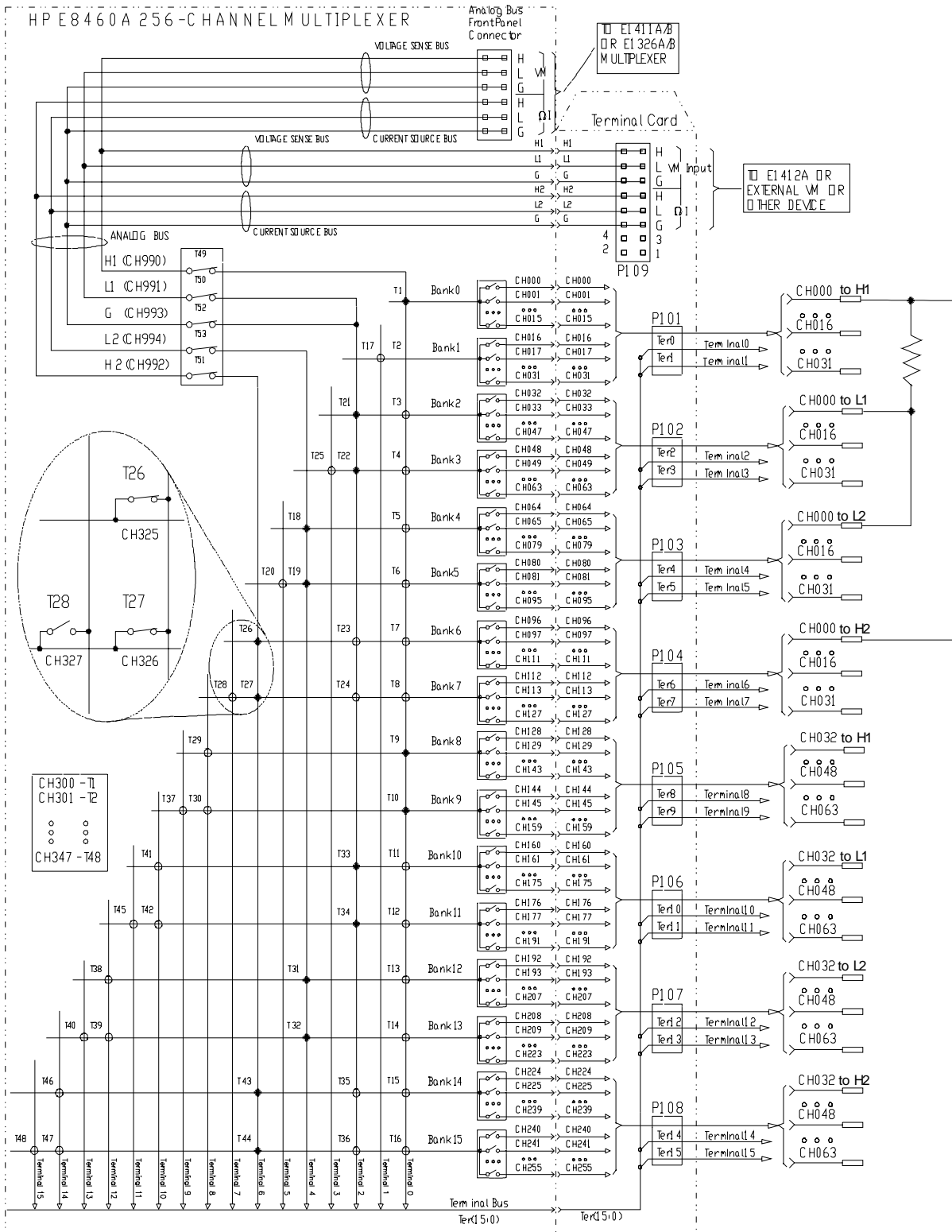

Figure 2-4. 3-Wire and 4-wire Operating Mode

Eight 32 x 1 Multiplexers

The HP E8460A can be configured as eight 32 x 1 multiplexers. In this configuration, the 256 channels are divided into 8 groups, each one is a 32 x 1 multiplexer. The 8 groups are connected to eight terminal bus (Terminals 0, 2, 4, 6, 8, 10, 12, 14) by closing 16 related tree relays. There are no commands to automatically set this mode; if you want to configure the eight 32x1 multiplexers, you must use the DIAG:CLOSE and DIAG:OPEN commands to set the appropriate tree relays.

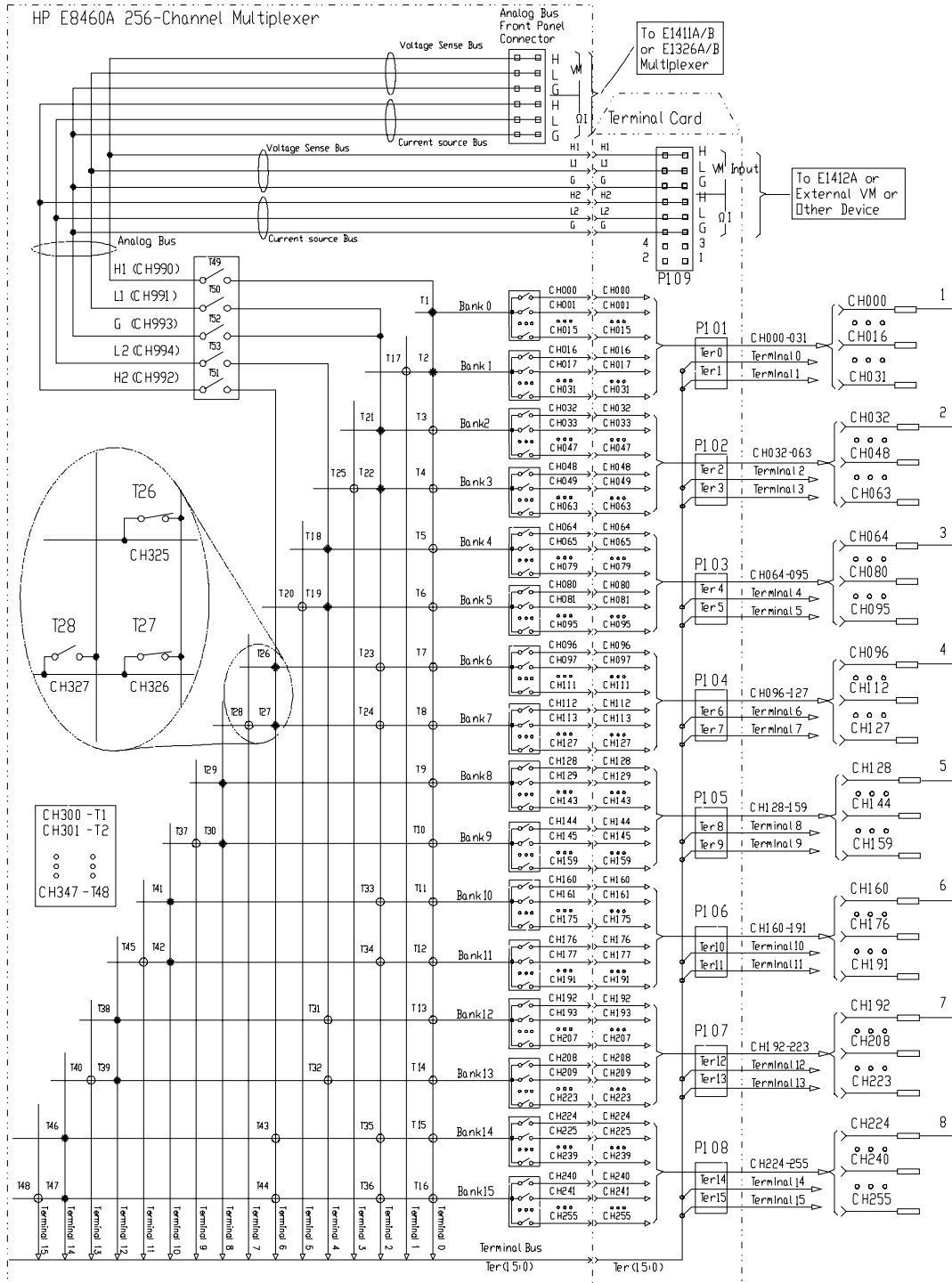

Figure 2-5. Eight 32 x 1 Multiplexer

Sixteen 16 x 1 Multiplexers

When this switching module is configured as sixteen 16 x 1 Multiplexer, the 16 closed tree relays (T1, T17-18, T20-21, T25-26, T28-29, T37-38, T40-41, T45-46, T48) will separate all the 256 channels into 16 groups and connect the specific group channel(s) to the related terminal(s). There are no commands to automatically set this mode; if you want to configure the sixteen 16x1 multiplexers, you must use the DIAG:CLOSE and DIAG:OPEN command to set the appropriate tree relays.

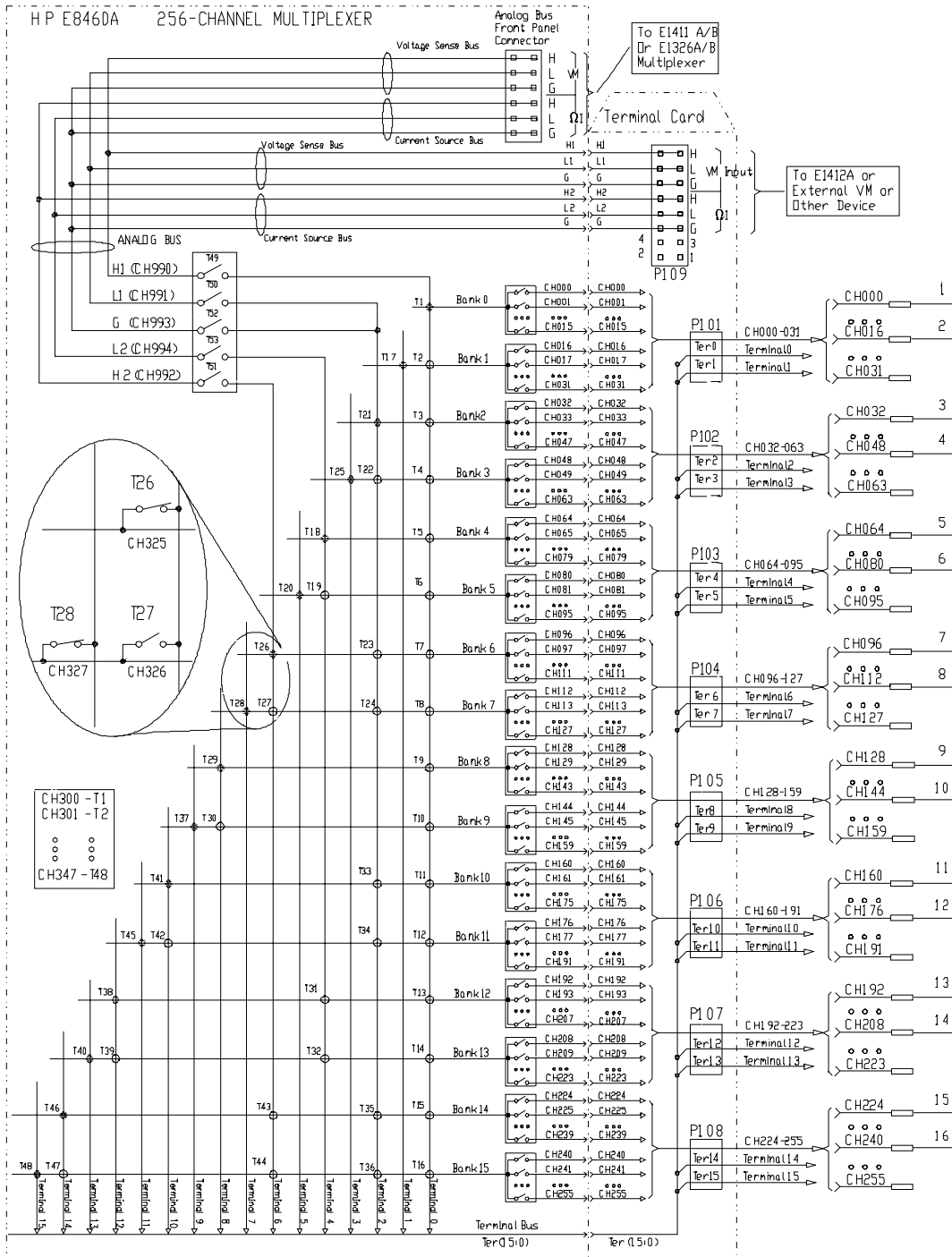

Figure 2-6. Sixteen 16 x 1 Multiplexer

Scanning Channels

Scanning the Multiplexer channels consists of sequentially closing a channel (and its associated tree relays), making some measurement, opening that channel, and then repeating that process with the next channel in a channel list. You can make a single scan through the channel list or scan a multiple number of times. You can also scan the channel list continuously until the scan is aborted.

The TRIGger:SOURce command specifies the source to advance the scan. The OUTPut command can be used to enable the HP E1406A Command Module's "Trig Out" port, TTL Trigger bus line (0-7) or ECL Trigger bus lines (0-1). Figure 2-7 illustrates the commands in the scanning sequence.

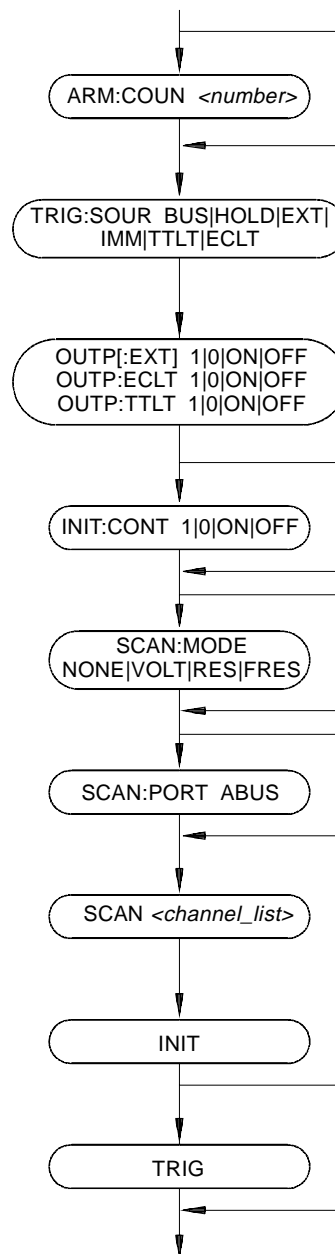

Figure 2-7. Command Sequence for Scanning Channels

You can scan a channel or a list of channels using the SCAN command. The analog bus connection control relays (CH990-994) are automatically closed when you specify the command SCAN:PORT ABUS. This command is required for the analog bus control relays to function during the scan through the channel list. The default value is SCAN:PORT NONE which does not allow these relays to operate and connect channels to the analog bus.

At power-on or after resetting the module with the *RST command, connection to the analog bus is disabled for scan operations. You must execute the command SCAN:PORT ABUS to enable analog bus connection control relay operation. Access is through the front panel analog bus connector (usually connected to other multiplexers or to the E1411A/B multimeter) or through the terminal module (Opt 014) “VM Input” and “Ω” terminals on P109 connector (see Figure 1-1 on page 13).

Synchronizing the Multiplexer with a Multimeter

This example uses the TTL VXibus triggers (TTLT 0-7) to synchronize channel closures with the HP E1412A 6-Digit Multimeter. DC Voltage measurements are performed. Measurement synchronization is attained by the multimeter sending a voltmeter complete signal on TT Trigger Line 1 and receiving the channel closed signal on TTL Trigger Line 0. Similarly, the multiplexer module sends its channel closed signal on TTL 0 and receives its channel advance signal on TTL 1. Note; Figure 2-8 shows connections between the HP E1406A Command Module Trigger In and Trigger Out to the HP E1412A Trigger In and Voltmeter Complete. This simply demonstrates an alternate method of synchronizing the measurements.

Measurement Set-Up

- HP E1412A has an HP-IB select code = 7, primary address = 09 and secondary address = 03.
- HP E8460A has an HP-IB select code = 7, primary address = 09 and secondary address = 14.
- Controller is an IBM compatible PC, the programming language is Visual C/C++ with HP VISA extensions.

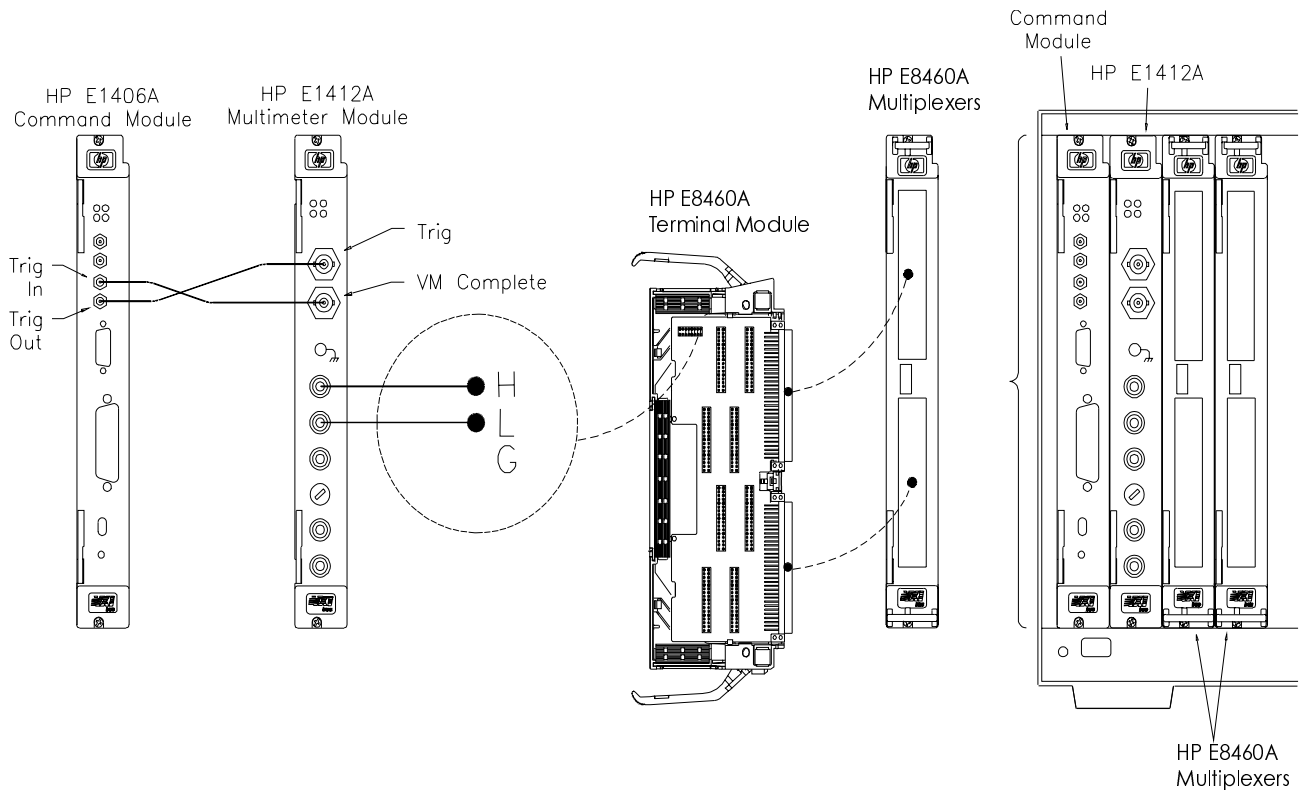

Figure 2-8. Scanning with VXIbus Triggers

The following example program was developed with the ANSI C language using the HP VISA extensions. The program was written and tested in Microsoft[®] Visual C++ but should compile under any standard ANSI C compiler.

To run the program you must have the HP SICL Library, the HP VISA extensions, and an HP 82340 or 82341 HP-IB module installed and properly configured in your PC. An HP E1406 Command Module is required.

This following example resets and configures the multimeter for DC Voltage measurements, resets and configures the multiplexer for 2-Wire configuration TTL Trigger bus synchronization, use of the analog bus, and scanning channels 00 through 09.

```
#include <visa.h>
#include <stdio.h>
#include <stdlib.h>

/* Interface address is 112, Module secondary address is 14*/
#define INSTR_ADDR "GPIB0::9::14::INSTR"
/* interface address for HP E1412 Multimeter */
#define MULTI_ADDR "GPIB0::9::3::INSTR"

int main()
{
    ViStatus errStatus; /*Status from each VISA call*/
```

```

ViSession viRM; /*Resource mgr. session */
ViSession E8460A; /* Module session */
ViSession E1412A; /* Multimeter session */
viSetAttribute (E1412A,VI_ATTR_TMO_VALUE,268435456)
/* multimeter timeout value */

int ii; /* loop counter */
char opc_int[21] /* OPC? variable */
double readings [10]; /* Reading Storage*/

/* Open the default resource manager */
errStatus = viOpenDefaultRM ( &viRM);
if(VI_SUCCESS > errStatus){
    printf("ERROR: viOpenDefaultRM() returned 0x%x\n",errStatus);
    return errStatus;}

/* Open the Module instrument session */
errStatus = viOpen(viRM,INSTR_ADDR, VI_NULL,VI_NULL,&E8460A);
if(VI_SUCCESS > errStatus){
    printf("ERROR: viOpen() returned 0x%x\n",errStatus);
    return errStatus;}

/* Open the Multimeter instrument session */
errStatus = viOpen(viRM,MULTI_ADDR, VI_NULL,VI_NULL,&E1412A);
if(VI_SUCCESS > errStatus){
    printf("ERROR: viOpen() returned 0x%x\n",errStatus);
    return errStatus;}

/* Reset the Multimeter, clear status system */
errStatus = viPrintf(E1412A, "**RST;*CLS\n");
if(VI_SUCCESS > errStatus){
    printf("ERROR: viPrintf() returned 0x%x\n",errStatus);
    return errStatus;}

/*Configure Multimeter for DCV measurements, 12 V max, min resolution */
errStatus = viPrintf(E1412A, "CONF:VOLT 12,MIN\n");
if(VI_SUCCESS > errStatus){
    printf("ERROR: viPrintf() returned 0x%x\n",errStatus);
    return errStatus;}

/* Set multimeter trig input TTL0 Trigger Line */
errStatus = viPrintf(E1412A, "TRIG:SOUR:TTL0\n");
if(VI_SUCCESS > errStatus){
    printf("ERROR: viPrintf() returned 0x%x\n",errStatus);
    return errStatus;}

/* Enable Measurement Complete on TTL2 */
errStatus = viPrintf(E1412A, "OUTP:TTL1 ON\n");
if(VI_SUCCESS > errStatus){
    printf("ERROR: viPrintf() returned 0x%x\n",errStatus);
    return errStatus;}

```



```

    /* Enable Trigger Delay */
errStatus = viPrintf(E1412A, "TRIG:DEL 0.001\n");
if(VI_SUCCESS > errStatus){
    printf("ERROR: viPrintf() returned 0x%x\n",errStatus);
    return errStatus;}

    /* Set Multimeter for 10 triggers */
errStatus = viPrintf(E1412A, "TRIG:COUN 10\n");
if(VI_SUCCESS > errStatus){
    printf("ERROR: viPrintf() returned 0x%x\n",errStatus);
    return errStatus;}

    /* Pause until multimeter is ready */
errStatus = viQueryf(E1412A, "**OPC?\n", "%t", opc_int);
if(VI_SUCCESS > errStatus){
    printf("ERROR: viQueryf() returned 0x%x\n",errStatus);
    return errStatus;}

    /* Initialize Multimeter, wait for trigger */
errStatus = viPrintf(E1412A, "INIT\n");
if(VI_SUCCESS > errStatus){
    printf("ERROR: viPrintf() returned 0x%x\n",errStatus);
    return errStatus;}

    /* Reset E8460A */
errStatus = viPrintf(E8460A, "**RST;*CLS\n");
if (VI_SUCCESS > errStatus) {
    printf("ERROR: viPrintf() returned 0x%x\n",errStatus);
    return errStatus;}

    /* Enable Trigger Output on TTL2 */
errStatus = viPrintf(E8460A, "OUTP:TTLT0 ON\n");
if(VI_SUCCESS > errStatus){
    printf("ERROR: viPrintf() returned 0x%x\n",errStatus);
    return errStatus;}

    /* Set Trigger Input On TTL 1 */
errStatus = viPrintf(E8460A, "TRIG:SOUR TTLT1\n");
if(VI_SUCCESS > errStatus){
    printf("ERROR: viPrintf() returned 0x%x\n",errStatus);
    return errStatus;}

    /* Set Multiplexer to 2-Wire mode */
errStatus = viPrintf(E8460A, "ROUT:FUNC ,WIRE2\n");
if(VI_SUCCESS > errStatus){
    printf("ERROR: viPrintf() returned 0x%x\n",errStatus);
    return errStatus;}

```

```

/* Set Multiplexer to Voltage mode */
errStatus = viPrintf(E8460A, "SCAN:MODE VOLT\n");
if(VI_SUCCESS > errStatus){
    printf("ERROR: viPrintf() returned 0x%x\n",errStatus);
    return errStatus;}

/* Enable Analog Bus */
errStatus = viPrintf(E8460A, "SCAN:PORT ABUS\n");
if(VI_SUCCESS > errStatus){
    printf("ERROR: viPrintf() returned 0x%x\n",errStatus);
    return errStatus;}

/* Set Scan List */
errStatus = viPrintf(E8460A, "SCAN(@1000:1009)\n");
if(VI_SUCCESS > errStatus){
    printf("ERROR: viPrintf() returned 0x%x\n",errStatus);
    return errStatus;}

/* Pause until ready */
errStatus = viQueryf(E8460A, "**OPC?\n","%t",opc_int);
if(VI_SUCCESS > errStatus){
    printf("ERROR: viQueryf() returned 0x%x\n",errStatus);
    return errStatus;}

/* Start Scan */
errStatus = viPrintf(E8460A, "INIT\n");
if(VI_SUCCESS > errStatus){
    printf("ERROR: viPrintf() returned 0x%x\n",errStatus);
    return errStatus;}

/* Get readings from Multimeter */
errStatus = viQueryf(E1412A, "FETC?\n","%,10lf",readings);
if(VI_SUCCESS > errStatus){
    printf("ERROR: viQueryf() returned 0x%x\n",errStatus);
    return errStatus;}

for (ii=0;ii<10;ii++) {
    printf (Reading %d is: %lf\n",ii,readings[ii]); }

/* Reset E8460A to open all channels*/
errStatus = viPrintf(E8460A,"*RST\n");
if (VI_SUCCESS > errStatus) {
    printf("ERROR: viPrintf() returned 0x%x\n",errStatus);
    return errStatus;}

/* Close the E8460A Instrument Session */
errStatus = viClose (E8460A);
if (VI_SUCCESS > errStatus) {
    printf("ERROR: viClose() returned 0x%x\n",errStatus);
    return 0;}

```

```
    /* Close the Multimeter Instrument Session */  
    errStatus = viClose (E1412A);  
    if (VI_SUCCESS > errStatus) {  
        printf("ERROR: viClose() returned 0x%x\n",errStatus);  
        return 0;}  
  
    /* Close the Resource Manager Session */  
    errStatus = viClose (viRM);  
    if (VI_SUCCESS > errStatus) {  
        printf("ERROR: viClose() returned 0x%x\n",errStatus);  
        return 0;}  
  
    return VI_SUCCESS;  
}
```

Using BUS Triggers with an External Device to Scan Channels

Refer to Figure 2-9. This example uses the BUS trigger (GET or *TRG) to synchronize channel closures with the HP 3457A Multimeter. A DC voltage measurement is performed. Measurement synchronization is attained by:

1. After the multimeter and multiplexer are configured, initiate the scan on the HP E8460A (INIT command). This closes the first channel.
2. FETCH? the reading from the multimeter.
3. Trigger the multiplexer (*TRG command). This opens the channel and closes the next channel in the list. After the relay settles, the HP E1406A outputs a trigger to trigger the multimeter.
4. Repeat steps 2 and 3 in a loop until all channels in the channel list have been scanned.

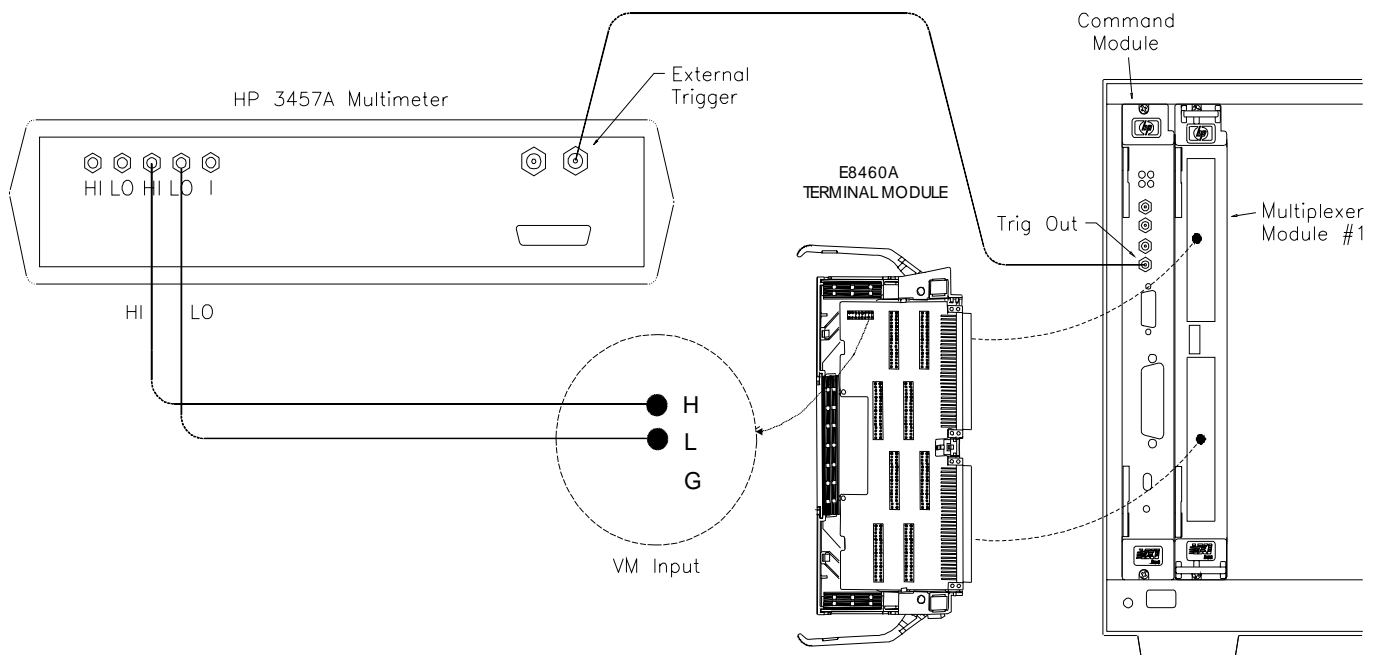

Figure 2-9. Scanning with an External Device

The actual C++ language program is similar to the previous example and will not be presented again.

Recalling and Saving States

This section contains information about saving and recalling a Multiplexer module state.

Saving States

The `*SAV <numeric_state>` command saves the current instrument state. The state number (0-9) is specified in the state parameter. The following settings are saved:

- Channel Relay State (CH000-256 open or closed);
- Tree Relay State (CH300-347 open or closed);
- Analog Bus Connection Control Relay State (CH990-994 open or closed)
- ARM:COUNT Value
- TRIGGER:SOURCE Mode
- OUTPUT[:STATE] Configuration
- INITiate:CONTinuous Mode
- [ROUTE:]SCAN:MODE Mode
- [ROUTE:]SCAN:PORT Mode

Recalling States

The `*RCL <numeric_state>` command recalls a previously saved state. Enter the number (0-9) in the state parameter of the desired saved state. If `*SAV` was not previously executed using the selected number, the Multiplexer will be configured to the reset values (see "Table 2-1. HP E8460A Default Conditions for Power-on and Reset" on page 35).

Note Scan lists are not saved when a state is saved. You must re-enter your scan list after recalling a state.

Detecting Error Conditions

There are two general approaches to error checking. The simplest, but most time consuming, is to ask the instrument whether there are errors at every step of the switching process. This is called “polling” and is illustrated in the two previous program examples.

Using Interrupts With Error Checking

The second approach involves the use of interrupts. In this approach, the program monitors the Multiplexer's Standard Event Status Register for an error condition. If no errors occur, the Multiplexer functions as programmed. If errors do occur, the Multiplexer interrupts the computer, and the error codes and messages are read from the error queue.

Chapter 3

Multiplexer Command Reference

Using This Chapter

This chapter describes Standard Commands for Programmable Instruments (SCPI) and summarizes IEEE 488.2 Common (*) commands applicable to the HP E8460A 256-Channel Multiplexer Module. This chapter contains the following sections.

- Command Types. page 55
- SCPI Command Reference page 58
- SCPI Command Quick Reference page 89
- IEEE 488.2 Common Command Reference page 90

Command Types

Commands are separated into two types: IEEE 488.2 Common Commands and SCPI Commands.

Common Command Format

The IEEE 488.2 standard defines the common commands that perform functions such as reset, self-test, status byte query, and so on. Common commands are four or five characters in length, always begin with the asterisk character (*), and may include one or more parameters. The command keyword is separated from the first parameter by a space character. Some examples of common commands are shown below:

*RST *ESR 32 *STB?

SCPI Command Format

The SCPI commands perform functions like closing switches, making measurements, and querying instrument states or retrieving data. A subsystem command structure is a hierarchical structure that usually consists of a top level (or root) command, one or more lower level commands, and their parameters. The following example shows part of a typical subsystem:

```
[ROUTE:]  
  CLOSe <channel_list>  
  SCAN <channel_list>  
    :MODE?
```

[ROUTE:] is the root command, CLOSe and SCAN are second level commands with parameters, and :MODE? is a third level command.

Command Separator

A colon (:) always separates one command from the next lower level command as shown below:

ROUTE:SCAN:MODE?

Colons separate the root command from the second level command (ROUTE:SCAN) and the second level from the third level (SCAN:MODE?).

Abbreviated Commands

The command syntax shows most commands as a mixture of upper and lower case letters. The upper case letters indicate the abbreviated spelling for the command. For shorter program lines, send the abbreviated form. For better program readability, you may send the entire command. The instrument will accept either the abbreviated form or the entire command.

For example, if the command syntax shows MEASure, then MEAS and MEASURE are both acceptable forms. Other forms of MEASure, such as MEASU or MEASUR will generate an error. You may use upper or lower case letters. Therefore, MEASURE, measure, and MeASUrE are all acceptable.

Implied Commands

Implied commands are those which appear in square brackets ([]) in the command syntax. (Note that the brackets are not part of the command and are not sent to the instrument.) Suppose you send a second level command but do not send the preceding implied command. In this case, the instrument assumes you intend to use the implied command and it responds as if you had sent it. Examine the partial [ROUTe:] subsystem shown below:

```
[ROUTe:]CLOSE <channel_list>
CLOSE? <channel_list>
OPEN <channel_list>
OPEN? <channel_list>
SCAN <channel_list>
:MODE <mode>
:MODE?
```

The root command [ROUTe:] is an implied command. To close relays in a channel list, you can send either of the following command statements:

```
ROUT:CLOS (@1000:1007, 2001, 2025) or CLOS (@1000:1007, 2001, 2025)
```

These commands function the same closing channels 0 through 7 on card 1 and channels 1 and 25 on card 2.

Parameters

Parameter Types. The following table contains explanations and examples of parameter types you might see later in this chapter.

Parameter Type	Explanations and Examples
Numeric	Accepts all commonly used decimal representations of number including optional signs, decimal points, and scientific notation. 123, 123E2, -123, -1.23E2, .123, 1.23E-2, 1.23000E-01. Special cases include MINimum, MAXimum, and DEFault.
Boolean	Represents a single binary condition that is either true or false ON, OFF, 1, 0
Discrete	Selects from a finite number of values. These parameters use mnemonics to represent each valid setting. An example is the TRIGger:SOURce <source> command where source can be BUS, EXT, HOLD, or IMM.

Optional Parameters. Parameters shown within square brackets ([]) are optional parameters. (Note that the brackets are not part of the command and are not sent to the instrument.) If you do not specify a value for an optional parameter, the instrument uses the default value. For example, consider the ARM:COUNT? [<MIN | MAX>] command. If you send the command without specifying a parameter, the present ARM:COUNT setting is returned. If you send the MIN parameter, the command returns the minimum count available. If you send the MAX parameter, the command returns the maximum count available. Be sure to place a space between the command and the parameter.

Linking Commands

Linking IEEE 488.2 Common Commands with SCPI Commands. Use a semicolon between the commands. For example:

```
*RST;OUTP ON or TRIG:SOUR HOLD;*TRG
```

Linking Multiple SCPI Commands. Use both a semicolon and a colon between the commands. For example:

```
ARM:COUN1;:TRIG:SOUR EXT
```

The **ABORt** command stops a scan in progress when the trigger sources are either TRIGger:SOURce BUS or TRIGger:SOURce HOLD. Refer to the comments below for how to get out of a scan if trigger source is not BUS or HOLD.

Subsystem Syntax

ABORt

Comments

- **Channel Status After an ABORt:** Aborting a scan will leave the last channel closed in the closed state.
- **Affect on Scan Complete Status Bit:** Aborting a scan will not set the “scan complete” status bit.
- **Stopping Scans Enabled from HP-IB Interface:** When a scan is enabled from the HP-IB interface, and the trigger source is not HOLD or BUS, you can clear the interface to stop the scan. When the scan is enabled from the HP-IB interface and the trigger source is TRIGger:SOURce BUS or TRIGger:SOURce HOLD; send the ABORt command over the HP-IB bus.

Note

Clearing the HP-IB interface during a scan leaves the last channel the scan closed in the closed position and does not set the “scan complete” status bit.

- **Stopping Scans by using a terminal¹:** You may use a terminal connected to the RS-232 (serial) port on the HP E1405/1406 command module to stop any scan.

If the scan was started from the terminal, and the trigger source is HOLD or BUS, send the ABORt command to halt the scan. If the scan was started from the terminal and some other trigger source is being used, a **Ctrl-c** will send an interface CLEAR to the instrument and abort the scan. Sending **Ctrl-r** also sends an interface CLEAR to the instrument and additionally performs a reset (*RST) on the instrument. (See your *HP E1405/E1406 Command Reference* for details on the terminal interface.)

If the scan was started from the HP-IB interface, but you wish to stop it by using the terminal, first make sure that the correct instrument (e.g., SWITCH at desired logical address) is selected by using the terminal soft keys. Then send a **Ctrl-r**. This will send an interface CLEAR to the HP-IB task, but will not place the instrument in the reset state with respect to the HP-IB task. These actions will occur regardless of the trigger source setting.

Note

Clearing the interface using a **Ctrl-c** from the terminal during a scan leaves the last channel it closed in the closed position and does not set the “scan complete” status bit.

1. Terminal refers to an RS-232 terminal connected to the HP E1405/E1406 Command Module’s RS-232 port.

- **Related Commands:** ARM, INITiate:CONTinuous, [ROUTE:]SCAN, TRIGger

Example Stopping a Scan with ABORT

```
TRIG:SOUR BUS  
INIT:CONT ON  
SCAN (@1000:1255)  
INIT  
.  
.  
ABOR
```

*Bus is trigger source.
Set continuous scanning.
Set channel list.
Start scanning cycle.

Abort scan in progress.*

The **ARM** subsystem allows a scan list to be scanned multiple times (1 through 32,767) with one **INITiate** command.

Subsystem Syntax **ARM:COUNT** *<number>* MIN | MAX
 :COUNT? [*<MIN | MAX>*]

ARM:COUNT

ARM:COUNT *<number>* **MIN | MAX** allows scanning cycles to occur a multiple of times (1 to 32,767) with one **INITiate** command when **INITiate:CONTinuous OFF|0** is set. **MIN** sets 1 cycle and **MAX** sets 32,767 cycles.

Parameters

Name	Type	Range of Values	Default Value
<i><number></i>	numeric	1 - 32,767 MIN MAX	1

Comments

- **Number of Scans:** Use only values between 1 (MIN) to 32767 (MAX) for the number of scanning cycles.
- **Related Commands:** **ABORt**, **INITiate[:IMMEDIATE]**, **INITiate:CONTinuous**
- ***RST Condition:** **ARM:COUNT1**

Example

Setting Ten Scanning Cycles

ARM:COUNT 10

Set 10 scanning cycles.

ARM:COUNT?

ARM:COUNT? [*<MIN | MAX>*] returns the current number of scanning cycles set by **ARM:COUNT**. If a value between **MIN** and **MAX** is set, that value for **ARM:COUNT** is returned. The optional parameters **MIN** and **MAX** allow you to query the module for these values instead of looking them up in the command reference. "1" is returned for the **MIN** parameter; "32767" is returned for the **MAX** parameter regardless of the **ARM:COUNT** value set.

Parameters

Name	Type	Range of Values	Default Value
<i><MIN MAX></i>	numeric	MIN = 1, MAX = 32,767	current cycles

Comments

- **Related Commands:** **INITiate[:IMMEDIATE]**

Example

Query Number of Scanning Cycles

ARM:COUNT 10
ARM:COUNT?

Set 10 scanning cycles.

Query number of scanning cycles.

The **DIAGnostic** subsystem controls setting and querying the Multiplexer's interrupt line, closing and opening specific channel relays regardless of the module's configuration mode. It also queries the state of specified channels.

Subsystem Syntax

```
DIAGnostic
:INTerrupt[:LINE] <card_number> <line_number>
:INTerrupt[:LINE]? <card_number>
:CLOSE <channel_list>
:CLOSE? <channel_list>
:OPEN <channel_list>
:OPEN? <channel_list>
:TEST?
```

DIAGnostic:INTerrupt[:LINE]

DIAGnostic:INTerrupt[:LINE] <card_number> <line_number> sets Multiplexer interrupt line. The *card_number* specifies which HP E8460A in a multiple-module switchbox, is being referred to. The *line_number* can be 1 through 7 corresponding to VXI backplane interrupt line 1-7.

Parameter

Name	Type	Range of Values	Default Value
<card_number>	numeric	1 - 99	1
<line_number>	numeric	0 - 7	1

Comments

- Setting <line_number> = 0 will disable the Multiplexer's interrupt.
- Only one value (1 through 7) can be set at one time.
- The default value of <line_number> is 1 (lowest interrupt line).

Example

Setting the Multiplexer's interrupt line equal to interrupt line 6.

```
DIAG:INT:LIN 1 6
```

Set the interrupt line equal to line 6.

DIAGnostic:INTerrupt[:LINE]?

DIAGnostic:INTerrupt[:LINE]? <card_number> queries the module's VXI backplane interrupt line and the return value is one of 1, 2, 3, 4, 5, 6, 7 which corresponding to the module's interrupt line 1-7. The return value being 0 indicates that the Multiplexer is interrupt disabled. The *card_number* specifies which HP E8460A in a multiple-module switchbox, is being referred to.

Parameter

Name	Type	Range of Values	Default Value
<card_number>	numeric	1 - 99	1

Comments

- Return value of "0" indicates that the Multiplexer's interrupt is disabled. Return values of 1-7 correspond to VXI backplane interrupt lines 1 through 7.
- When power-on or reset the module, the default interrupt line is 1.

Example

Query the Multiplexer's interrupt line.

```
DIAG:INT:LIN 6
DIAG:INT:LIN?
```

*Set the interrupt line equal to 6.
Query the Multiplexer's interrupt line.*

DIAGnostic:CLOSe

DIAGnostic:CLOSe <channel_list> closes channels specified in *channel_list* regardless of the Multiplexer's configurations. *Channel_list* is in the form (@ccnnn), (@ccnnn,ccnnn), or (@ccnnn:ccnnn) or any combination of above, where cc = card number (01-99) and nnn = channel number (000-255, 300-347 and 990-994). Refer to "Figure 1-1. HP E8460A Simplified Schematic" on page 13.

Parameters

Name	Type	Range of Values	Descriptions
<channel_list>	numeric	cc000 - cc255; cc300 - cc347; cc990 - cc994.	Channel Relays Tree Relays Analog Bus Relays

Comments

- **Closing Channels:** To close:
 - a single channel use DIAG:CLOS (@ccnnn);
 - multiple channels use DIAG:CLOS (@ccnnn,ccnnn,...);
 - sequential channels use DIAG:CLOS (@ccnnn:ccnnn);
 - groups of sequential channels use
DIAG:CLOS (@ccnnn:ccnnn,ccnnn:ccnnn);
 - or any combination of the above.

Opening order for multiple channels with a single command is not guaranteed. A list of channels will not all open simultaneously. Use sequential OPEN commands if needed.

- **Special Case of Using Upper Range 999 in the Channel List:** Specifying the last channel as 999 e.g., (@1000:1999) automatically closes all channels on the card number specified by cc including 256 channel relays (CH000-255) and 48 tree relays T1-T48 (CH300-347) and 5 analog bus connection relays T49-T52 (CH990-994).
- **Related Commands:** DIAG:OPEN <channel_list>, DIAG:CLOSe?
- ***RST Condition:** All Multiplexer channels are open.

Caution Executing this command causes the specified channels to close without opening any other channels or any checking by the firmware. To prevent unexpected short circuits or other undesirable results, be very careful when specifying which channels to close.

Example Closing Multiple Channels of Multiplexer.

```
DIAG:CLOS (@1000,1015)           Close channels 000 and 015 of
                                  multiplexer #1.
```

DIAGnostic:CLOSe?

DIAG:CLOSe? <channel_list> returns the current state of the channel(s) queried. *Channel_list* is in the form (@cnnn). The command returns “1” if the channel is closed or returns “0” if the channel is open. If a list of channels is queried, a comma delineated list of 0 or 1 values is returned in the same order of the channel list.

Comments

- **Query is Software Read-back:** The DIAGnostic:CLOSe? command returns the current state of the register controlling the specified channel. It does not account for a failed relay, relay driver circuit, or a relay closed by direct register access (see Appendix B).

Example Query Multiplexer Channel Closure.

```
DIAG:CLOS (@1000,1015)           Close channels 000 and 015 of
                                  multiplexer #1.
DIAG:CLOS? (@1015)              Query channel 15 of multiplexer #1 and
                                  the returned value is 1.
```

DIAGnostic:OPEN

DIAGnostic:OPEN <channel_list> opens the Multiplexer channel(s) specified in the *channel_list* regardless of the Multiplexer's configurations. The *channel_list* is in the form (@ccnn), (@ccnn,ccnn), or (@ccnn:ccnn) where cc = card number (01-99) and nn = channel number (000-255, 300-347 and 990-994).

Parameters

Name	Type	Range of Values	Descriptions
<channel_list>	numeric	cc000 - cc255; cc300 - cc347; cc990-cc994.	Channel Relays Tree Relays Analog Bus Relays

Comments

- **Using Upper Range 999 in the Channel List:** Specifying the last channel as 999, e.g., (@1000:1999), automatically opens all channels on the specific card including the tree relays (CH300-347) and analog bus connection relays CH990-994).

- **Opening Channels:** To open:

- a single channel use DIAG:OPEN (@ccnnn);
- multiple channels use DIAG:OPEN (@ccnnn,ccnnn,...);
- sequential channels use DIAG:OPEN (@ccnnn:ccnnn);
- groups of sequential channels use
DIAG:OPEN (@ccnnn:ccnnn,ccnnn:ccnnn);
- or any combination of the above.

Opening order for multiple channels with a single command is not guaranteed. A list of channels will not all open simultaneously. Use sequential OPEN commands if needed.

- **Related Commands:** DIAG:CLOSe, DIAG:OPEN?
- ***RST Condition:** All channels open.

Example

Opening Multiplexer Channels

DIAG:OPEN (@1000,1255)

Open channels 000 and 255 of multiplexer #1.

DIAGnostic:OPEN?

DIAGnostic:OPEN? <*channel_list*> returns the current state of the channel(s) queried. *Channel_list* has the form (@ccnn). The command returns “1” if the channel is open or “0” if the channel is closed. If a list of channels is queried, a comma delineated list of 0 or 1 values is returned in the same order of the channel list.

- Comments**
- **Query is Software Read-back:** The DIAGnostic:OPEN? command returns the current state of the register controlling the specified channel. It does not account for a failed relay, relay driver circuit, or a relay closed by direct register access (see Appendix B).

Example Query Multiplexer Channels Open State.

DIAG:OPEN (@1000,1063,1316)

Open channels 000 and 063 of multiplexer #1

DIAG:OPEN? (@1000,1316)

Query channel 000 and 316 (tree relay) of multiplexer #1. The returned value 1,1 indicates that the channels 000 & 316 are open.

DIAGnostic:TEST?

DIAGnostic:TEST? causes the instrument to perform a self test which includes writing to and reading from all relay registers and verifying the correct values. A failure may indicate a potential hardware problem.

- Comments**
- **Returned Value:** Returns 0 if all tests passed; otherwise the card fails.
 - **Error Codes:** If the card fails, the returned value is in the form *10*card number + error code*. Error codes are:
 - 1 = Internal driver error;
 - 2 = VXI bus timeout;
 - 3 = Card ID register incorrect;
 - 5 = Card data register incorrect;
 - 10 = Card did not interrupt;
 - 11 = Card busy time incorrect;
 - 40 = Relay register read and written data don't match.

Caution **Disconnect the terminal block or terminal modules or any other external devices when performing this function.**

Example Perform the diagnostic test to check whether the module has error(s):

DIAG:TEST?

Returned value can be either 0 or other value. “0” indicates that the system has passed the self test otherwise the system has an error.

The **INITiate** command subsystem selects continuous scanning cycles and starts the scanning cycle.

Subsystem Syntax

```
INITiate
:CONTinuous <mode>
:CONTinuous?
[:IMMediate]
```

INITiate:CONTinuous

INITiate:CONTinuous <mode> enables or disables continuous scanning cycles for the Multiplexer.

Parameters

Name	Type	Range of Values	Default Value
<mode>	boolean	ON OFF 1 0	OFF 0

Comments

- **Continuous Scanning Operation:** Continuous scanning is enabled with the INITiate:CONTinuous ON or INITiate:CONTinuous 1 command. Sending the INITiate:IMMediate command closes the first channel in the channel list. Each trigger from the trigger source specified by the TRIGger:SOURce command advances the scan through the channel list. A trigger at the end of the channel list closes the first channel in the channel list and the scan cycle repeats.
- **Noncontinuous Scanning Operation:** Noncontinuous scanning is enabled with the INITiate:CONTinuous OFF or INITiate:CONTinuous 0 command. Sending the INITiate:IMMediate command closes the first channel in the channel list. Each trigger from the trigger source specified by the TRIGger:SOURce command advances the scan through the channel list. A trigger at the end of the channel list opens the last channel in the list and the scanning cycle stops.
- The INITiate:CONTinuous command does not start a scanning cycle (refer to INITiate[:IMMediate] command).
- **Stopping Continuous Scan:** Refer to the ABORt command.
- **Related Commands:** ABORt, ARM:COUNT, INITiate[:IMMediate], TRIGger:SOURce
- ***RST Condition:** INITiate:CONTinuous OFF|0

Example Enabling Continuous Scans

```
INIT:CONT ON
SCAN (@1000:1255)
SCAN (@1990:1994)
INIT
```

*Enable continuous scanning.
Set channel list.
Set channel list.
Start scanning cycle.*

INITiate:CONTInuous?

INITiate:CONTInuous? queries the scanning state. With continuous scanning enabled, the command returns “1” (ON). With continuous scanning disabled, the command returns “0” (OFF).

Example Query Continuous Scanning State

```
INIT:CONT ON
INIT:CONT?
```

*Enable continuous scanning.
Query continuous scanning state. It
returns “1” (ON).*

INITiate[:IMMediate]

INITiate[:IMMediate] starts the scanning process and closes the first channel in the channel list. Successive triggers from the source specified by the TRIGger:SOURce command advances the scan through the channel list.

Comments

- **Starting the Scanning Cycle:** The INITiate:IMMediate command starts scanning by closing the first channel in the channel list. Each trigger received advances the scan to the next channel in the channel list. An invalid channel list generates an error (refer to [ROUTE:]SCAN).
- **Stopping Scanning Cycles:** Refer to the ABORt command.
- **Related Commands:** ABORt, ARM:COUNT, INITiate:CONTInuous, TRIGger, TRIGger:SOURce
- ***RST Condition:** None

Example Starting a Single Scan

```
SCAN (@1000:1255)
INIT
```

*Set channel list.
Start scanning cycle by closing channel
000 and proceeding.*

The **OUTPut** command subsystem enables or disables an active trigger line for the HP E1405A/B or E1406A Command Module. Note that triggers are not actually generated by the HP E8460A Multiplexer module; triggers are generated by the controller.

Subsystem Syntax

```

OUTPut
  :ECLTrgn[:STATe]
  :ECLTrgn[:STATe]?
  [:EXTeRnal]
    [:STATe] <mode>
    [:STATe]?
  :TTLTrgn (:TTLTrg0 through:TTLTrg7)
    [:STATe] <mode>
    [:STATe]?
  
```

OUTPut:ECLTrgn[:STATe]

OUTPut:ECLTrgn[:STATe] <mode> enables (ON or 1) or disables (OFF or 0) the ECL trigger bus pulse on the VXI bus line specified by *n*. There are two ECL trigger lines on the VXI bus allowing valid values for *n* to be 0 and 1. “mode” enables (ON or 1) or disables (OFF or 0) the specified ECL Trigger bus line.

Parameters

Name	Type	Range of Values	Default Value
<i>n</i>	numeric	0 or 1	N/A
<mode>	boolean	0 1 OFF ON	OFF 0

Comments

- When **OUTPut:ECLTrgn:STATe ON** is set, a trigger pulse occurs each time a channel is closed during a scan. The output is a negative going pulse.
- **One Output Selected at a Time:** Only one output can be enabled at one time. Enabling a different output source will automatically disable the active output.
- Valid values for *n* are 0 and 1.

OUTPut:ECLTrgn[:STATe]?

OUTPut:ECLTrgn[:STATe]? queries the state of the ECL trigger bus line specified by *n*. A “1” is returned if the line is enabled; a “0” is returned if it is disabled. Valid values for *n* are 0 and 1.

OUTPut[:EXTeRnal][:STATe]

OUTPut[:EXTeRnal][:STATe] <mode> enables or disables the “Trig Out” port on the HP E1406A command module.

- OUTPut[:EXTeRnal][:STATe] ON|1 enables the port
- OUTPut[:EXTeRnal][:STATe] OFF|0 disables the port.

Parameters

Name	Type	Range of Values	Default Value
<mode>	boolean	ON OFF 1 0	OFF 0

Comments

- **Enabling “Trig Out” Port:** When enabled, the “Trig Out” is pulsed each time a channel is closed during scanning. When disabled, the “Trig Out” is not pulsed.
- **Output Pulse:** The pulse is a +5 V negative going pulse.
- **“Trig Out” Port Shared by Multiplexers:** Once enabled, the “Trig Out” port may be pulsed by the multiplexer each time a channel is closed in a multiplexer during scanning. To disable the output for a specific multiplexer, send the OUTPut[:EXTeRnal][:STATe] OFF or OUTPut[:EXTeRnal][:STATe] 0 command for that multiplexer. The OUTP OFF command must be executed following use of this port to allow other instrument drivers to control the “Trig Out” port.
- **Related Commands:** [ROUTe:]SCAN, TRIGger:SOURce
- ***RST Condition:** OUTPut:EXTeRnal[:STATe] OFF (port disabled)

Example Enabling “Trig Out” Port

OUTP ON

Enable "Trig Out" port for pulse output.

OUTPut[:EXTeRnal][:STATe]?

OUTPut[:EXTeRnal][:STATe]? queries the present state of the “Trig Out” port on the E1405/E1406. The command returns “1” if the port is enabled, or “0” if disabled.

Example Query “Trig Out” Port State

OUTP ON
OUTP:STAT?

*Enable "Trig Out" port for pulse output.
Query port enable state.*

OUTPut:TTLTrgn[:STATe]

OUTPut:TTLTrgn[:STATe] *<mode>* selects and enables which TTL Trigger bus line (0 to 7) will output a trigger when a channel is closed during a scan. This is also used to disable a selected TTL Trigger bus line. “*n*” specifies the TTL Trigger bus line (0 to 7) and “*mode*” enables (ON or 1) or disables (OFF or 0) the specified TTL Trigger bus line.

Parameters

Name	Type	Range of Values	Default Value
<i>n</i>	numeric	0 to 7	N/A
<i><mode></i>	boolean	ON OFF 1 0	OFF 0

Comments

- When **OUTPut:TTLTrgn:STATe ON** is set, a trigger pulse occurs each time a channel is closed during a scan. The output is a negative going pulse.
- **One Output Selected at a Time:** Only one output can be enabled at one time. Enabling a different output source will automatically disable the active output.
- **Related Commands:** [ROUTE:]SCAN, TRIGger:SOURce, OUTPut:TTLTrgn[:STATe]?
- ***RST Condition:** OUTPut:TTLTrgn[:STATe] OFF (disabled)

Example Enabling TTL Trigger Bus Line 7

```
OUTP:TTLT7:STAT 1
```

Enable TTL Trigger bus line 7 to output pulse after each scanned channel is closed.

OUTPut:TTLTrgn[:STATe]?

OUTPut:TTLTrgn[:STATe]? queries the present state of the specified TTL Trigger bus line. The command returns “1” if the specified TTLTrg bus line is enabled or “0” if disabled. Valid values for *n* are 0 and 1.

Example Query TTL Trigger Bus Enable State

This example enables TTL Trigger bus line 7 and queries the enable state. The **OUTPut:TTLTrgn?** command returns “1” since the port is enabled.

```
OUTP:TTLT7:STAT 1  
OUTP:TTLT7?
```

*Enable TTL Trigger bus line 7.
Query bus enable state.*

The [ROUTe:] command subsystem controls switching and scanning operations for the Multiplexer module(s). For HP E8460A, the commands CLOSe and OPEN can not open/close the 48 tree relays, which are controlled either by the system's specific operating mode or by the commands DIAG:CLOSe and DIAG:OPEN.

Subsystem Syntax

```
[ROUTe:]
  CLOSe <channel_list>
  CLOSe? <channel_list>
  FUNCtion <card_number>, <mode>
  FUNCtion? <card_number>
  OPEN <channel_list>
  OPEN? <channel_list>
  SCAN <channel_list>
    :MODE <mode>
    :MODE?
    :PORT <port>
    :PORT?
```

[ROUTe:]CLOSe

[ROUTe:]CLOSe <channel_list> closes Multiplexer channels specified in the *channel_list*. *Channel_list* is in the form (@ccnnn), (@ccnnn,ccnnn), or (@ccnnn:ccnnn) where cc = card number (01-99) and nnn = channel number.

Parameters

Name	Type	Range of Values	Operating Mode
<channel_list>	numeric	cc000-cc255, cc990-cc994; cc000-cc127, cc990-cc994; cc000-cc063, cc990-cc994; cc000-cc063, cc990-cc994.	1-wire 2-wire 3-wire 4-wire

Comments

- **Specifying Operating Mode:** The operating mode must be specified BEFORE using this command to close the specific channels.
- **Tree Relays:** The command [ROUTe:]CLOSe and [ROUTe:]OPEN can not close the 48 tree relays (CH300-347) which are either configured by the command FUNCtion or controlled by DIAGnostic:CLOSe and DIAGnostic:OPEN.
- **Channel Number:** The tree relays (CH300-347) and analog bus connection relays (CH990-994) have the same channel number no matter what operating mode the Multiplexer is. The channel relays (CH000-255) may have different channel number under different modes. The following table lists the channel number under different modes.

Operating Mode	Valid Channel Number	Corresponding Relays
1-wire	000-255	000-255
2-wire	000-127	000-031, 064-095, 128-159, 192-223
3-wire	000-063	000-031, 128-159
4-wire	000-063	000-031, 128-159

Channel Pairs: The 256 channels form different channel pairs under different operating mode. Once one channel is selected to be closed/opened/scanned, the paired channel(s) will be closed/opened/scanned automatically. For example, under 4-wire mode, Banks 0/2/4/6 are the first 4-wire pair and Bank 8/10/12/14 are another 4-wire pair, once channel 000 (Bank0) is closed, the paired channels 032, 048 and 096 are also closed automatically. So do the channels 128, 160, 192 and 224. The following table lists the channel pairs under different modes; refer to Chapter 2 for diagrams showing the channels and modes.

Operating Mode	Valid Channel Numbers	Corresponds to 1-wire Channels	Channel Pair
1-wire	000-255	000-255	256 1-wire
2-wire	000-127	000-031, 064-095, 128-159, 192-223	128 2-wire pairs: Bank 0/2, 1/3, 4/6, 5/7, 8/10, 9/11, 12/14, 13/15
3-wire	000-063	000-031,128-159	64 3-wire pairs: Bank 0/2/4, 1/3/5, 8/10/12, 9/11/13 Bank 6,7,14,15 not used
4-wire	000-063	000-031, 128-159	64 4-wire pairs: Bank 0/2/4/6, 1/3/5/7, 8/10/12/14, 9/11/13/15

• **Closing Channels:** To close:

- a single channel use CLOS (@ccnnn);
- multiple channels use CLOS (@ccnnn,ccnnn...);
- sequential channels use CLOS (@ccnnn:ccnnn);
- groups of sequential channels use CLOS (@ccnnn:ccnnn,ccnnn:ccnnn);
- or any combination of the above.

Closure order for multiple channels with a single command is not guaranteed. A list of channels will not all close simultaneously. The order channels close when specified from a single command is not guaranteed. Use sequential CLOS commands if needed.

Note To close/open/scan a channel is actually to close/open/scan one paired channel. Under 2-wire mode, it is to close/open/scan one 2-wire pair, under 4-wire mode, is to close/open a 4-wire pair.

- **Special Case of Using Upper Range 999 in the Channel List:** Specifying the last channel as 999 e.g., (@1000:1999) automatically closes all channels on the card number specified by cc **NOT INCLUDING** tree relays T1-T48 (CH300-347).
- **Related Commands:** [ROUTE:]OPEN, [ROUTE:]CLOSE?
- ***RST Condition:** All multiplexer channels are open.

Example Closing Multiplexer Channels to Perform 2-wire Measurement.

This example closes channels 000 and 032.

FUNC 1, WIRE2

Configure the Multiplexer to 2-wire mode.

CLOS (@1000)

Close channel 000, the channel 032 will be paired with 000 and closed together.

Make 2-Wire Measurement

OPEN (@1000)

Open the channels 000 & 032 after measurement.

[ROUTE:]CLOSE?

[ROUTE:]CLOSE? <channel_list> returns the current state of the channel(s) queried. *Channel_list* is in the form (@ccnnn). The command returns “1” if the channel is closed or returns “0” if the channel is open. If a list of channels is queried, a comma delineated list of 0 or 1 values is returned in the same order of the channel list.

Comments

- **Query is Software Readback:** The ROUTE:CLOSE? command returns the current state of the hardware controlling the specified channel. It does not account for a failed relay or a relay closed by direct register access (see Appendix B).
- **Channel_list:** See [ROUTE:]CLOSE for *channel_list* definition.

Example Query Multiplexer Channel Closure

FUNC 1, WIRE4

Configure the module to 4-wire mode.

CLOS (@1000,1032)

Close channels 000, 032, 048, 096 and 128, 160, 192, 224 (two 4-wire pairs)

CLOS? (@1000,1032)

Returned value “1,1” indicates that the paired channels 000 & 032 are closed.

[ROUTE:]FUNCTION

[ROUTE:]FUNCTION <card_number>, <mode> selects the operating mode of the Multiplexer channels. All the channels on the card specified by *card_number* operate in the specified mode. When power on or reset the Multiplexer, the default function is NONE (all the relays including the tree relays and analog bus connection relays are open). Refer to Chapter 2 for additional information on channel pairing.

Parameters

Name	Type	Range of Values	Default Value
<card_number>	numeric	01 to 99	N/A
mode	discrete	NONE WIRE1 WIRE2 WIRE3 WIRE4	NONE

Comments

- When this command is executed, the tree relays (Ch300 - Ch347) appropriate for the specified mode, are closed. All other channel relays are opened. The tree relays will remain in the specified state unless a DIAG:CLOSE or DIAG:OPEN command is executed to change their state or another ROUTE:FUNCTION command is executed to change the mode..
- **1-Wire Mode:** This mode configures the Multiplexer module as a 1 x 256 Multiplexer. The tree relays T1 through T16 are closed and all the channels are connected to TER0 and only one of the 256 1-wire channels can be closed at a time. Additionally, the valid channel_list to open/close/scan is 000-255.
- **2-Wire Mode:** Sets the 2-Wire mode; all the 256 channels form 128 2-wire pairs. To close/open/scan one channel is actually to close/open/scan a 2-wire pair.
- **3-Wire Mode:** Sets the 3-Wire mode to the specific terminals 0, 2 and 4. Only 192 channels form 64 3-wire pairs which are the valid channel number to be closed/opened/scanned. Other 64 channels (Bank 6, 7, 14, 15) are not used.
- **4-Wire Mode:** Sets the 4-wire mode. The valid channel_list to open/close/scan is 000-064. All the 256 channels form 64 4-wire pairs which are the valid channel number can be closed/opened/scanned.

Note For more information of **channel paired** and **channel number** under different operating mode, refer to the comments of command [ROUTE:]CLOSE on page 71.

Related Commands: [ROUTE:]OPEN, [ROUTE:]CLOSE, [ROUTE:]SCAN.

***RST Condition:** The Multiplexer is set to NONE mode (all channels are open).

Example Configure Multiplexer Mode

This example configures Multiplexer card #1 to 4-wire operating mode.

```
FUNC 1,WIRE4  
CLOS (@1000, 1032)
```

*Configure card #1 to 4-wire mode.
Close 4-wire paired channels 000 & 032,
actually eight channels (CH000, 032,
064, 096, 128, 160, 192 & 224).*

[ROUTe:]FUNcTion?

[ROUTe:]FUNcTion? <card_number> returns the current operating mode of the card(s) queried. See [ROUTe:]FUNcTion for *card_number* definition. The command returns NONE | WIRE1 | WIRE2 | WIRE3 | WIRE4.

Example Query Operating Mode

This example sets card #1 to 2-wire mode and queries the operating mode.

```
FUNC 1,WIRE2
FUNC? 1
```

*Configure card #1 to 2-wire mode.
Query operating mode of card #1. The returned value "WIRE2" indicates that the card is under 2-wire operating mode.*

[ROUTe:]OPEN

[ROUTe:]OPEN <channel_list> opens the Multiplexer channels specified in the *channel_list*. The *channel_list* is in the form (@ccnnn), (@ccnnn,ccnnn), or (@ccnnn:ccnnn) where cc = card number (01-99) and nnn = channel number. This command cannot open the 48 tree relays.

Parameters

Name	Type	Range of Values	Operating Mode
<channel_list>	numeric	cc000-cc255, cc990-cc994; cc000-cc127, cc990-cc994; cc000-cc063, cc990-cc994; cc000-cc063, cc990-cc994.	1-wire 2-wire 3-wire 4-wire

Comments

- **Using Upper Range 99 in the Channel List:** Specifying the last channel as 999 will automatically open all channels on the card number specified by cc NOT INCLUDING tree relays 1 through 48 (CH300-347).
- **Channel_list, Channel Paired:** See [ROUTe:]CLOSE for detailed information.
- **Opening Channels:** To open:
 - a single channel use OPEN (@ccnnn);
 - multiple channels use OPEN (@ccnnn,ccnnn,...);
 - sequential channels use OPEN (@ccnnn:ccnnn);
 - groups of sequential channels use OPEN (@ccnnn:ccnnn,ccnnn:ccnnn);
 - or any combination of the above.

Opening order for multiple channels with a single command is not guaranteed. A list of channels will not all open simultaneously. Use sequential OPEN commands if needed.

- **Related Commands:** [ROUTe:]CLOSE, [ROUTe:]OPEN?

- ***RST Condition:** All channels open.

Example Opening Multiplexer Channels.

This example opens all the channels of Multiplexer under 1-wire operating mode.

```
FUNC 1, WIRE1                               Select the Multiplexer's operating mode.
OPEN (@1000:1255)                            Open all the channels of the Multiplexer.
```

[ROUTE:]OPEN?

[ROUTE:]OPEN? <channel_list> returns the current state of the channel(s) queried. *Channel_list* has the form (@ccnnn). The command returns “1” if the channel is open or “0” if the channel is closed. If a list of channels is queried, a comma delineated list of 0 or 1 values is returned in the same order of the channel list.

Comments

- **Query is Software Readback:** The ROUTE:OPEN? command returns the current state of the hardware controlling the specified channel. It does not account for a failed switch element.
- **Channel_list:** See [ROUTE:]CLOSE on page 71 for *channel_list* definition.

Example Query Multiplexer Channel Open State

```
FUNC 1, WIRE2                               Set the Multiplexer to 2-wire mode.
OPEN (@1000,1015)                            Open 2-wire paired channels 000 and 015.

OPEN? (@1015)                                Query channel 015 and the returned value "1" indicates that the channel is open.
```

[ROUTE:]SCAN

[ROUTE:]SCAN <channel_list> defines the channels to be scanned. *Channel_list* is in the form (@ccnnn), (@ccnnn,ccnnn), or (@ccnnn:ccnnn) where cc = card number (01-99) and nnn = channel number.

Parameters

Name	Type	Range of Values	Operating Mode
<channel_list>	numeric	cc000-cc255, cc990-cc994; cc000-cc127, cc990-cc994; cc000-cc063, cc990-cc994; cc000-cc063, cc990-cc994.	1-wire 2-wire 3-wire 4-wire

Comments

- **Special Case of Using Upper Range 999 in the Channel List:** Specifying the last channel as 999, e.g. (@1000:1999), automatically scans all channels on the card number specified by cc **BUT DOES NOT** close tree relays (CH300-347).
- **Defining Scan List:** When ROUTE:SCAN is executed, the channel list is checked for valid card and channel numbers. An error is generated for an invalid channel list. See [ROUTE:]CLOSE on page 71 for more information of

channel_list and **channel paired**.

- **Scanning Operation:** When a valid channel list is defined, INITiate[:IMMEDIATE] begins the scan and closes the first channel in the *channel_list*. Successive triggers from the source specified by TRIGger:SOURce advance the scan through the channel list.
- **Operating Mode:** The operating mode must be specified first then you can define the channels or channel range to be scanned.
- **Stopping Scan:** See the ABORt command on page 58.
- **Related Commands:** [ROUTE:]CLOSe, [ROUTE:]OPeN, [ROUTE:]SCAN:MODE, [ROUTE:]SCAN:PORT, TRIGger, TRIGger:SOURce
- ***RST Condition:** All channels open.

[ROUTE:]SCAN:MODE

[ROUTE:]SCAN:MODE *<mode>* sets the Multiplexer channels defined by the [ROUTE:]SCAN *<channel_list>* command for none, volts, 2-wire ohms, or 4-wire ohms measurements. These settings determine which tree relays, if any, connect to the analog bus.

Parameters

Name	Type	Range of Values	Default Value
<i><mode></i>	discrete	NONE VOLT RES FRES	NONE

Comments

- **Order of Command Execution:** [ROUTE:]SCAN:MODE must be executed before [ROUTE:]SCAN *<channel_list>* because SCAN:MODE erases the current SCAN list.
- **Function Modes:** Because the tree relays are automatically set by the ROUTe:FUNCTION command, not every scan mode is available for all function modes. Function modes WIRE4 and WIRE3 allow every scan mode. Function mode WIRE2 allows scan modes NONE, VOLT, and RES. Function mode WIRE1 only allows scan mode NONE.
- **Channel Numbers:** The valid channel numbers are defined by the function mode. For example, in function mode WIRE4, valid channel numbers are 0-63, each channel number closes four relays. If the scan mode is VOLT (which is a 2-wire mode), when CLOSe or OPeN are executed, four channels will open/close. But when a scan is executed, only the proper two relays are opened/closed. When scan mode is NONE, only the lowest channel is opened/closed.
- **NONE Mode:** When selected, *channel_list* is not setup for specific measurement. Scanning will close or open the lowest numbered channel each time regardless of whether the channel is paired.

- **VOLT Mode:** When selected, *channel_list* is setup for two wire voltage measurement. The valid *channel_list* is cc000-cc127.
- **RES Mode:** When selected, *channel_list* is setup for two wire resistance measurements. The valid *channel_list* is the same as VOLT mode.
- **FRES Mode:** When selected, *channel_list* is setup for four-wire ohms measurements. The valid *channel_list* is cc000-cc063.

Note See [ROUTe:]CLOSe on page 71 for the paired channel information.

- **Related Commands:** [ROUTe:]SCAN
- ***RST Condition:** [ROUTe:]SCAN:MODE NONE

[ROUTe:]SCAN:MODE?

[ROUTe:]SCAN:MODE? Returns the current state of the scan mode. The command returns NONE, VOLT, RES, or FRES if the scan mode is in the none, volts, 2-wire ohms, or 4-wire ohms measurement mode respectively.

Example Query Scan Mode

Since this example selects the FRES (4-wire ohms) mode, the query command returns FRES.

```
SCAN:MODE FRES
SCAN:MODE?
```

*Select the 4-wire ohms scanning mode.
Query the scanning mode.*

[ROUTe:]SCAN:PORT

[ROUTe:]SCAN:PORT <port> enables/disables the closing/opening of the analog bus connection control relays (CH990-994) during scanning. SCAN:PORT ABUS closes these control relays for analog bus connections. ROUTe:SCAN:PORT NONE prevents closing or opening the analog bus connection control relays (this is useful if your measurement instrument is not connected to the analog bus).

Parameters

Name	Type	Range of Values	Default Value
<port>	discrete	ABUS NONE	NONE

Comments

- **Order of Command Execution:** The [ROUTe:]SCAN:PORT command can be executed after the [ROUTe:]SCAN <*channel_list*> command but must occur before the scan is initiated with the INIT command.
- ***RST Condition:** [ROUTe:]SCAN:PORT NONE. NOTE: *RST opens all switches on the card and resets the port to ROUTe:SCAN:PORT NONE. Most uses of this multiplexer will require use of ROUTe:SCAN:PORT ABUS to allow subsequent channel connection to the analog bus.

Example Selecting the ABUS Port

```
TRIG:SOUR EXT
SCAN:MODE FRES
SCAN:PORT ABUS
SCAN (@1000:1007)
INIT
```

Select external trigger source.
Select the 4-wire ohms scanning mode.
Select the ABUS port.
Set channel list.
Start scanning cycle.

[ROUTe:]SCAN:PORT?

[ROUTe:]SCAN:PORT? <port> queries the current state of the analog bus connection control relays (CH990-994). The command returns a string, either ABUS or NONE.

The **STATus** subsystem reports the bit values of the Operation Status Register. It also allows you to unmask the bits you want reported from the Standard Event Register and to read the summary bits from the Status Byte Register.

Subsystem Syntax

```
STATus
:OPERation
:CONDition?
:ENABle <unmask>
:ENABle?
[:EVENT?]
:PRESet
```

The STATus system contains four registers (that is, they reside in a SCPI driver, not in the hardware), two of which are under IEEE 488.2 control; the Standard Event Status Register (*ESE?) and the Status Byte Register (*STB?). The operational status bit (OPR), service request bit (RQS), standard event summary bit (ESB), message available bit (MAV) and questionable data bit (QUE) in the Status Byte Register (bits 7, 6, 5, 4 and 3 respectively) can be queried with the *STB? command. Use the *ESE? command to query the “unmask” value for the Standard Event Status Register (the bits you want logically OR'd into the summary bit). The registers are queried using decimal weighted bit values. The decimal equivalents for bits 0 through 15 are included in "Figure 3-1. E8460A Status System Register Diagram" on page 83.

A numeric value of 256 executed in a STAT:OPER:ENABle <unmask> command allows only bit 8 to generate a summary bit. The decimal value for bit 8 is 256.

The decimal values are also used in the inverse manner to determine which bits are set from the total value returned by an EVENT or CONDition query. The “SWITCH” driver exploits only bit 8 of Operation Status Register. This bit is called the scan complete bit which is set whenever a scan operation completes. Since completion of a scan operation is an event in time, you will find that bit 8 will never appear set when STAT:OPER:COND? is queried. However, you can find bit 8 set with the STAT:OPER:EVENT? query command.

STATus:OPERation:CONDition?

STATus:OPERation:CONDition? returns the state of the Condition Register in the Operation Status Group. The state represents conditions which are part of the instrument's operation. The "SWITCH" driver does not set bit 8 in this register (see STATus:OPERation[:EVENT]?).

STATus:OPERation:ENABLE

STATus:OPERation:ENABLE <unmask> sets an enable mask to allow events recorded in the Event Register to send a summary bit to the Status Byte Register (bit 7). For Multiplexer modules, when bit 8 in the Operation Status Register is set to 1 and that bit is enabled by the STATus:OPERation:ENABLE command, bit 7 in the Status Register is set to 1.

Parameters

Name	Type	Range of Values	Default Value
<unmask>	numeric	0 through 65,535	N/A

Comments

- **Setting Bit 7 of the Status Register:** STATus:OPERation:ENABLE 256 sets bit 7 of the Status Register to 1 after bit 8 of the Operation Status Register is set to 1.
- **Related Commands:** [ROUTE:]SCAN

Example

Enabling Operation Status Register Bit 8

STAT:OPER:ENAB 256

Enable bit 8 of the Operation Status Register to be reported to bit 7 (OPR) in the Status Register.

STATus:OPERation:ENABLE?

STATus:OPERation:ENABLE? returns which bits in the Event Register (Operation Status Group) are unmasked.

Comments

- **Output Format:** Returns a decimal weighted value from 0 to 65,535 indicating which bits are set to true.
- **Maximum Value Returned:** The value returned is the value set by the STAT:OPER:ENAB <unmask> command. However, the maximum decimal weighted value used in this module is 256 (bit 8 set to true).

Example

Query the Operation Status Enable Register

STAT:OPER:ENAB?

Query the Operation Status Enable Register.

STATus:OPERation[:EVENT]?

STATus:OPERation[:EVENT]? returns which bits in the Event Register (Operation Status Group) are set. The Event Register indicates when there has been a time-related instrument event.

Comments

- **Setting Bit 8 of the Operation Status Register:** Bit 8 (scan complete) is set to 1 after a scanning cycle completes. Bit 8 returns to 0 (zero) after sending the STATus:OPERation[:EVENT]? command.
- **Returned Data after sending the STATus:OPERation[:EVENT]? Command:** The command returns “+256” if bit 8 of the Operation Status Register is set to 1. The command returns “+0” if bit 8 of the Operation Status Register is set to 0.
- **Event Register Cleared:** Reading the Event Register with the STATus:OPERation:EVENT? command clears it.
- **Aborting a Scan:** Aborting a scan will leave bit 8 set to 0.
- **Related Commands:** [ROUTE:]SCAN

Example

Reading the Operation Status Register After a Scanning Cycle

STAT:OPER?

read the register value

Return the bit values of the Operation Status Register.

+256 shows bit 8 is set to 1; +0 shows bit 8 is set to 0.

STATus:PRESet

STATus:PRESet affects only the Enable Register by setting all Enable Register bits to 0. It does not affect either the “status byte” or the “standard event status”. PRESet does not clear any of the Event Registers.

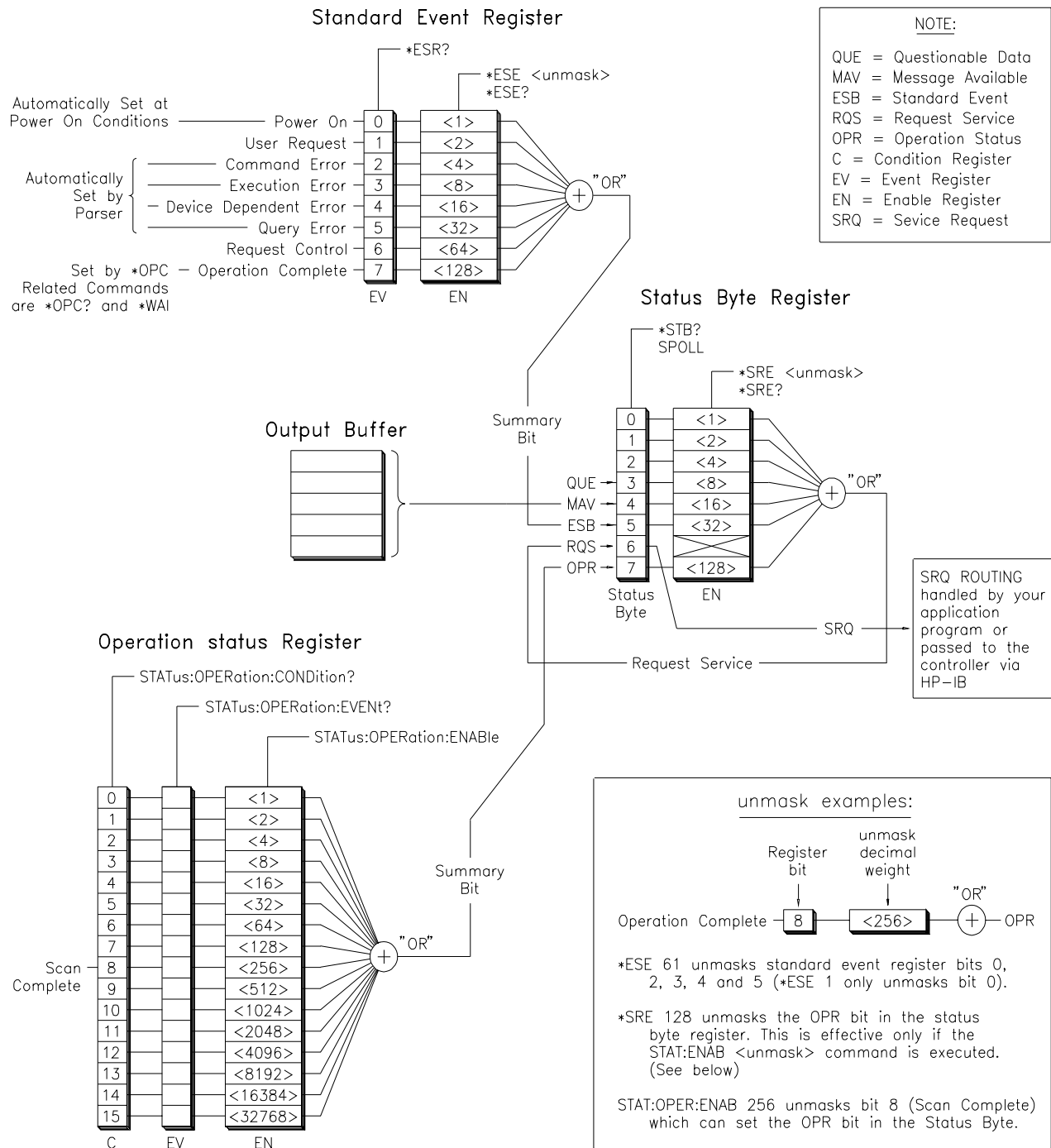

Figure 3-1. E8460A Status System Register Diagram

The **SYSTEM** subsystem returns the error numbers and error messages in the error queue of the multiplexer. It can also return the types and descriptions of module.

Subsystem Syntax

```
SYSTEM
:CDEscription? <number>
:CPON <number> | ALL
:CTYPe? <number>
:ERRor?
```

SYSTEM:CDEscription?

SYSTEM:CDEscription? <number> returns the description of a selected module in a multiple-module configuration.

Parameters

Name	Type	Range of Values	Default Value
<number>	numeric	1 through 99	N/A

Comments

- **256-Channel Multiplexer Module Description:** The SYSTEM:CDEscription? command returns:

“256-Channel Multiplexer”

Example

Reading the Description of a Card #1 Module

```
SYST:CDES? 1
```

Return the description.

SYSTEM:CPON

SYSTEM:CPON <number> | ALL resets the selected module, or multiple modules to their power-on state.

Parameters

Name	Type	Range of Values	Default Value
<number>	numeric	1 through 99	N/A

Comments

Differences between *RST and CPON: SYSTEM:CPON ALL and *RST opens all channels of single or multiple modules, while SYSTEM:CPON <number> opens the channels in only the module (card) specified in the command.

Example

Setting Card #1 Module to its Power-on State

```
SYST:CPON 1
```

Set module #1 channels to power-on state (open).

SYSTem:CTYPe?

SYSTem:CTYPe? <number> returns the module type of a selected module.

Parameters

Name	Type	Range of Values	Default Value
<number>	numeric	1 through 99	N/A

Comments

- **HP E8460A 256-Channel Relay Multiplexer Module Model Number:** The SYSTem:CTYPe? <number> command returns:

HEWLETT-PACKARD , E8460A , 0 , A . 08 . 00

where the 0 after E8460A is the module serial number (always 0) and A.08.00 is an example of the module revision code number.

Example

Reading the Model Number of a Card #1 Module

SYST:CTYP? 1

Return the model number.

SYSTem:ERRor?

SYSTem:ERRor? returns the error numbers and corresponding error messages in the error queue of a multiplexer. See Appendix C for a listing of multiplexer error numbers and messages.

Comments

- **Error Numbers/Messages in the Error Queue:** Each error generated by a multiplexer stores an error number and corresponding error message in the error queue. The error message can be up to 255 characters long, but typically is much shorter.
- **Clearing the Error Queue:** An error number/message is removed from the queue each time the SYSTem:ERRor? command is sent. The errors are cleared first-in, first-out. When the queue is empty, each following SYSTem:ERRor? query returns: +0, "No error". To clear all error numbers/messages in the queue, execute the *CLS command.
- **Maximum Error Numbers/Messages in the Error Queue:** The queue holds a maximum of 30 error numbers/messages for the multiplexer. If the queue overflows, the last error number/message in the queue is replaced by: -350, "Too many errors". The least recent (oldest) error numbers/messages remain in the queue and the most recent are discarded.

Example

Reading the Error Queue

SYST:ERR?

Query the error queue.

The **TRIGger** command subsystem controls the triggering operation of the Multiplexer.

Subsystem Syntax TRIGger
 [:IMMediate]
 :SOURce <source>
 :SOURce?

TRIGger[:IMMediate]

TRIGger[:IMMediate] causes a trigger to occur when the defined trigger source is TRIGger:SOURce BUS or TRIGger:SOURce HOLD. This can be used to trigger a suspended scan operation.

Comments

- **Executing the TRIGger[:IMMediate] Command:** A channel list must be defined with [ROUTe:]SCAN <channel_list> and an INITiate[:IMMediate] command must be executed before TRIGger[:IMMediate] will execute.
- **BUS or HOLD Source Remains:** If selected, the TRIGger:SOURce BUS or TRIGger:SOURce HOLD commands remain in effect after triggering a multiplexer with the TRIGger[:IMMediate] command.
- **Related Commands:** INITiate, [ROUTe:]SCAN, TRIGger:SOURce

Example

Advancing Scan Using TRIGger Command

```
TRIG:SOUR HOLD
SCAN (@1000:1255)
INIT
loop statement
TRIG
increment loop
```

```
Set trigger source to HOLD.
Define channel list.
Start scanning cycle.
Start count loop.
Advance scan to next channel.
Increment loop count.
```

TRIGger:SOURce

TRIGger:SOURce <source> specifies the trigger source to advance the channel list during scanning.

Parameters

Name	Type	Parameter Description
BUS	discrete	*TRG or GET command
ECLTrgn	numeric	ECL Trigger bus line 0 or 1
EXTErnal	discrete	"Trig In" port
HOLD	discrete	Hold Triggering
IMMediate	discrete	Immediate Triggering
TTLTrgn	numeric	TTL Trigger bus line 0 - 7

Comments

- **Enabling the Trigger Source:** The TRIGger:SOURce command only selects the trigger source. The INITiate[:IMMediate] command enables the trigger source. The trigger source must be selected using the TRIGger:SOURce command before executing the INIT command.
- **One Trigger Input Selected at a Time:** Only one input (ECLTrg0 or 1; TTLTrg0, 1, 2, 3, 4, 5, 6 or 7; or EXTErnal) can be selected at one time. Enabling a different trigger source will automatically disable the active input. For example, if TTLTrg1 is the active input, and TTLTrg4 is enabled, TTLTrg1 will become disabled and TTLTrg4 will become the active input.
- **Using the TRIGger Command:** You can use TRIGger[:IMMediate] to advance the scan when TRIGger:SOURce BUS or TRIGger:SOURce HOLD is selected.
- **Using External Trigger Inputs:** With TRIGger:SOURce EXTErnal selected, only one multiplexer at a time can use the external trigger input at the HP E1406A "Trig In" port.
- **Using TTL or ECL Trigger Bus Inputs:** These triggers are from the VXI backplane trigger lines ECL[0,1] and TTL[0-7]. These may be used to trigger the "SWITCH" driver from other VXI instruments.
- **Using EXTErnal, TTLTrgn, and ECLTrgn Trigger Inputs:** After using TRIGger:SOURce EXT|TTLTrgn|ECLTrgn, the selected trigger source remains assigned to the "SWITCH" driver until it is relinquished through use of the TRIG:SOUR BUS|HOLD command. While the trigger is in use by the "SWITCH" driver, no other drivers operating on the E1405/E1406 command module will have access to that particular trigger source. Likewise, other drivers may consume trigger resources which may deny access to a particular trigger by the "SWITCH" driver. You should always release custody of trigger sources after completion of an activity by setting the trigger source to BUS or HOLD (i.e. TRIG:SOUR BUS|HOLD).

- **Using Bus Triggers:** To trigger the multiplexer with TRIGger:SOURce BUS selected, use the IEEE 488.2 common command *TRG or the HP-IB Group Execute Trigger (GET) command.
- **“Trig Out” Port Shared by Multiplexers:** See the OUTPut command on page 68.
- **Related Commands:** ABORt, [ROUte:]SCAN, OUTPut
- ***RST Condition:** TRIGger:SOURceIMMediate

Example Scanning Using External Triggers

In the following example, the trigger input is applied to the HP E1405/E1406 command module's “Trig In” port.

TRIG:SOUR EXT	<i>Set trigger source to external.</i>
SCAN (@1000:1255)	<i>Set channel list.</i>
INIT	<i>Start scanning cycle.</i>
(trigger externally)	<i>Advance channel list to next channel.</i>

Example Scanning Using Bus Triggers

TRIG:SOUR BUS	<i>Set trigger source to bus.</i>
SCAN (@1000:1255)	<i>Set channel list.</i>
INIT	<i>Start scanning cycle.</i>
*TRG	<i>Advance channel list to next channel.</i>

TRIGger:SOURce?

TRIGger:SOURce? returns the current trigger source for the multiplexer: BUS, EXT, HOLD, IMM, TTLT0-7, or ECLT0-1 for sources BUS, EXTErnal, HOLD, IMMEDIATE, TTLTrgn, or ECLTrgn, respectively.

Example Querying the Trigger Source

This example sets external triggering and queries the trigger source. Since external triggering is set, TRIG:SOUR? returns “EXT”.

TRIG:SOUR EXT	<i>Set external trigger source.</i>
TRIG:SOUR?	<i>Query trigger source.</i>

SCPI Command Quick Reference

The following table summarizes the SCPI commands for the Multiplexer.

Command		Description
ABORt		Abort a scan in progress.
ARM	:COUNT <number> :COUNT? [MIN MAX]	Multiple scans per INIT command. Query number of scans.
DIAGnostic	:CLOSe <channel_list> :CLOSe? <channel_list> :OPEN <channel_list> :OPEN? <channel_list> :INTerrupt:[LINE] <number> :INTerrupt:[LINE]? :TEST?	Close multiplexer channels specified regardless of the configuration. Query multiplexer channels specified in the <i>channel_list</i> . Open multiplexer channels specified regardless of the configuration. Query separate channels specified in the <i>channel_list</i> . Set interrupt line of multiplexer. Query interrupt line. Do diagnostic to fix specific error(s).
INITiate	:CONTinuous ON OFF :CONTinuous? [:IMMediate]	Enables/disables continuous scanning. Query continuous scan state. Starts a scanning cycle.
OUTPut	:ECLTrgn[:STATe] ON OFF 1 0 :ECLTrgn[:STATe]? [:EXternal][:STATe] ON OFF 1 0 [:EXternal][:STATe]? :TTLTrgn[:STATe] ON OFF 1 0 :TTLTrgn[:STATe]?	Enables/disables the specified ECL trigger line. Query the specified ECL trigger line. Enables/disables the "Trig Out" port on the command module. Query the external state. Enables/disables the specified TTL trigger line. Query the specified TTL trigger line.
[ROUte:]	CLOSe <channel_list> CLOSe? <channel_list> FUNctIon <card_number>, <mode> FUNctIon? <card_number> OPEN <channel_list> OPEN? <channel_list> SCAN <channel_list> SCAN:MODE <mode> SCAN:MODE? SCAN:PORT <port>	Close channel(s). Query channel(s) closed. Set operating mode to WIRE1, WIRE2, WIRE3 and WIRE4. Query the current operating mode. Open channel(s). Query channel(s) opened. Define channels for scanning. Sets scan mode to NONE, VOLT, RES, or FRES. Query the scan mode. Enables channel connections to the analog bus (ABUS or NONE).
STATus	:OPERation:CONDition? :OPERation:ENABLE <unmask> :OPERation:ENABLE? :OPERation:EVENT?<mask> :PRESet	Returns contents of the Operation Condition Register. Enables events in the Operation Event Register to be reported. Returns the unmask value set by the :ENABLE command. Returns the contents of the Operation Event Register Sets Enable Register bits to 0.
SYSTem	:CDEscription? <number> :CPON <number> ALL :CTYPe? <number> :ERRor?	Returns description of module. Opens all channels on specified module(s) .Returns the module type .Returns error number/message in a multiplexer error queue.
TRIGger	[:IMMediate] :SOURce BUS :SOURce ECLTrgn :SOURce EXternal :SOURce HOLD :SOURce IMMEDIATE :SOURce TTLTrgn :SOURce?	Causes a trigger to occur. Trigger source is *TRG. Trigger is the VXIbus ECL trigger bus line n. Trigger source is "Trig In" (on the E1405 or E1406). Hold off triggering. Trigger source is the internal triggers. Trigger is the VXIbus TTL trigger bus line n. Query scan trigger source.

IEEE 488.2 Common Command Reference

The following table lists the IEEE 488.2 Common (*) Commands accepted by the HP E8460A Multiplexer. For more information on Common Commands, refer to the HP 75000 Series C Mainframe (HP Model Number E1400/E1401) User's Manual or the ANSI/IEEE Standard 488.2-1987.

Command	Command Description
*CLS	Clears all status registers (see STATus:OPERation[:EVENT]?) and clears the error queue.
*ESE <register value>	Enable Standard Event.
*ESE?	Enable Standard Event Query.
*ESR?	Standard Event Register Query.
*IDN?	Instrument ID Query; returns identification string of the module.
*OPC	Operation Complete.
*OPC?	Operation Complete Query.
*RCL <numeric state>	Recalls the instrument state saved by *SAV. You must reconfigure the scan list.
*RST	Resets the module. Opens all channels and invalidates current channel list for scanning. Sets ARM:COUN 1, TRIG:SOUR IMM, and INIT:CONT OFF.
*SAV <numeric state>	Stores the instrument state but does not save the scan list.
*SRE <register value>	Service request enable, enables status register bits.
*SRE?	Service request enable query.
*STB?	Read status byte query.
*TRG	Triggers the module to advance the scan when scan is enabled and trigger source is TRIGger:SOURce BUS.
*TST?	Self-test. Executes an internal self-test and returns only the first error encountered. Does not return multiple errors. The following is a list of responses you can obtain where "cc" is the card number with the leading zero deleted. +0 if self test passes. +cc01 for firmware error. +cc02 for bus error (problem communicating with the module). +cc03 for incorrect ID information read back from the module's ID register. +cc05 for hardware and firmware have different values. Possibly a hardware fault or an outside entity is register programming the E8460A. +cc10 if an interrupt was expected but not received. +cc11 if the busy bit was not held for a sufficient amount of time.
*WAI	Wait to Complete.

Note These commands apply to many instruments. See the *HP 75000 Series C E1400/E1401 Mainframe User's Manual* or the ANSI/IEEE Standard 488.2-1987 for more information about these commands. The common commands *RCL, *SAV and *TST? do specific actions with the E8460A and are described in the above table.

Appendix A

HP E8460A Specifications

General Characteristics

Module Size/Device Type C-Size VXIbus, Register based, A16/D16

Interrupt Level 1-7, selectable

Cooling/Slot Watts/slot: 8.5W
 ΔP mm H₂O: 0.05
Air Flow (liters/sec):0.7

Operating Temperature 0 - 55°C

Operating Humidity 65% RH, 0 - 40°C

Operating Location Intended for indoor use only. Operating location should be a sheltered location where air temperature and humidity are controlled within this product's specifications and the product is protected against direct exposure to climatic conditions such as direct sunlight, wind, rain, snow, sleet and icing, water spray or splash, hoarfrost or dew.

Pollution Environment Pollution environment for which this product may be operated is IEC 664 Pollution Degree 2 (typically, indoor). Pollution degree 2 means only non-conductive pollution occurs. However, occasionally a temporary conductivity caused by condensation must be expected.

Power Requirements

Voltage	I _{pm} (A)	I _{dm} (A)
+5V	1.7 ¹	0.40
+12V	0.0	0.0
-12V	0.0	0.0

**Relay Life
(typical)**

Condition	Number of Operations
1.0 V & 10 mA	500 x 10 ⁶
Rated Full Resistive Load	10 x 10 ⁶

NOTE: Relays are subject to normal wear out based on the number of operations.

1. Specified with 128 (one-half) of the relays closed.

Input Characteristics

These limits apply only if no connection is made to power mains.

Maximum Input

	With Option 012 Crimp & Insert Terminal Card	With Opt. 014 Fault Tolerant Terminal Card	With Opt. 015 Ribbon Cable Conn Terminal Card	Analog Bus
Maximum DC Voltage	200 V ^a	60 V	60 V	60 V
Max. ACrms Voltage	140 V	50 V ^b	50V ^b	30 V
Max. ACpeak Voltage	200 V	70.7 V	70.7 V	42 V
Maximum Current per Channel: Switching: Carry:	300 mA 500 mA	100 mA 100 mA	100 mA 100 mA	N/A N/A

a. Replace the Crimp and Insert connector after 10,000 hours of operation of switching over 50V ACrms or 60V DC. Refer to Chapter 1 of this manual.

b. Rating reduced to 30V ACrms, 42V ACpeak for exposed conductors.

Caution Due to the close terminal spacing and the potential for pin-to-pin leakage, the terminal connector blocks on the HP E8460A Option 012 Crimp and Insert Terminal Card must be replaced after 10,000 hours of use if the module regularly switches voltages greater than 60VDC, 50VACrms, or 70.7 VACpeak.

DC Performance (Typical)

Thermal offset per Channel: $\pm 50\mu\text{V}$

Closed Channel Resistance: $< 3\Omega$ with output protection resistor shorted; protection resistor adds 100Ω .

AC Performance (Typical)

Bandwidth, 50Ω Source/Load:

Configuration	100Ω Protection Resistor Shorted
256:1	4.5 MHz
64:1	12.0 MHz
16:1	30.0 MHz

Closed Channel Capacitance:

Configuration	to Chassis	To open Channel
256:1	1400 pF	70 pF
64:1	460 pF	70 pF
16:1	140 pF	70 pF

Open channel to either open channel or to Chassis) Capacitance: 70 pF

Hi-to-Lo Capacitance (2-Wire Mode):

Configuration	Capacitance
128:1	400 pF
64:1	230 pF
16:1	80 pF

Crosstalk:

Configuration	10kHz	100kHz	1MHz	10MHz
256:1	84 dB	64 dB	44 dB	30 dB
64:1	84 dB	64 dB	44 dB	27 dB
16:1	83 dB	64 dB	44 dB	24 dB

Relay Life

Electromechanical relays are subject to normal wear-out. Relay life depends on several factors. The effects of loading and switching frequency are briefly discussed below.

Relay Load. In general, higher power switching reduces relay life. In addition, capacitive/inductive loads and high inrush currents (for example, turning on a lamp or starting a motor) reduces relay life. Exceeding specified maximum inputs can cause catastrophic failure.

Switching Frequency. Relay contacts heat up when switched. As the switching frequency increases, the contacts have less time to dissipate heat. The resulting increase in contact temperature also reduces relay life.

End-of-Life Detection

A preventative maintenance routine can prevent problems caused by unexpected relay failure. The end of the life of the relay can be determined by using one or more of the three methods described below. The best method (or combination of methods), as well as the failure criteria, depends on the application in which the relay is used.

Contact Resistance. As the relay begins to wear out, its contact resistance increases. When the resistance exceeds a predetermined value, the relay should be replaced.

Stability of Contact Resistance. The stability of the contact resistance decreases with age. Using this method, the contact resistance is measured several (5 - 10) times, and the variance of the measurements is determined. AN increase in the variance indicates deteriorating performance.

Number of Operations. Relays can be replaced after a predetermined number of contact closures. However, this method requires knowledge of the applied load and life specifications for the applied load. Typical relay life is 500×10^6 relay closures with no load or 10×10^6 relay closures switching full load.

Replacement Strategy

The replacement strategy depends on the application. If some relays are used more often, or at a higher load, than the others, the relays can be individually replaced as needed. If all relays see similar loads and switching frequencies, the entire circuit board can be replaced when the end of relay life approaches. The sensitivity of the application should be weighed against the cost of replacing relays with some useful life remaining.

Note Relays that wear out normally or fail due to misuse should not be considered defective and are not covered by the product's warranty.

Appendix B

Register-Based Programming

About This Appendix

The HP E8462A 256-Channel Relay Multiplexer is a register-based module which does not support the VXIbus word serial protocol. When a SCPI command is sent to the multiplexer, the instrument driver parses the command and programs the multiplexer at the register level.

Register-based programming is a series of reads and writes directly to the multiplexer registers. This increases throughput speed since it eliminates command parsing and allows the use of an embedded controller. Also, register programming provides an avenue for users to control a VXI module with an alternate VXI controller device and eliminates the need for using an HP E1405/E1406 Command Module.

This appendix contains the information you need for register-based programming. The contents include:

- Register Addressing Page 95
- Register Descriptions Page 99
- Program Timing and Execution Page 106
- Programming Examples Page 108

Register Addressing

Register addresses for register-based devices are located in the upper 25% of VXI A16 address space. Every VXI device (up to 256 devices) is allocated a 32 word (64 byte) block of addresses. Figure B-1 shows the register address location within A16 as it might be mapped by an embedded controller. Figure B-2 shows the location of A16 address space in the HP E1405A/B and E1406A Command modules.

The Base Address

When you are reading from, or writing to, a multiplexer register, a hexadecimal or decimal register address is specified. This address consists of a base address plus a register offset.

The base address used in register-based programming depends on whether the A16 address space is outside or inside the HP E1406A Command Module.

A16 Address Space Outside the Command Module

When the HP E1406A Command Module is not part of your VXIbus system (Figure B-1), the multiplexer's base address is computed as:¹

$$C000_h + (LADDR * 64)_h$$

or (decimal)

$$49,152 + (LADDR * 64)$$

where C000_h (49,152) is the starting location of the register addresses, LADDR is the multiplexer's logical address, and 64₁₀ is the number of address bytes per VXI device. For example, the multiplexer's factory set logical address is 112 (70_h). If this address is not changed, the multiplexer will have a base address of:

$$C000_h + (112 * 64)_h = C000_h + 1C00_h = DC00_h$$

or (decimal)

$$49,152 + (112 * 64) = 49,152 + 7168 = 56,320$$

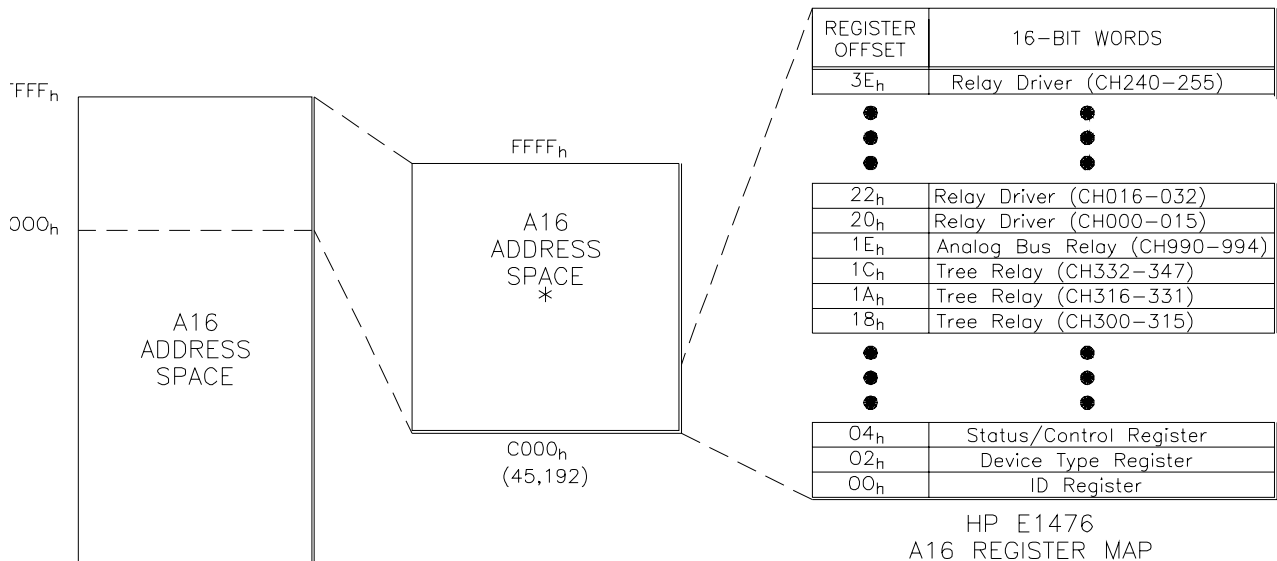

* Base Address = C000_h + (Logical Address * 64)_h
 or
 45,192 + (Logical Address * 64)

Register Address = Base address + Register Offset

Figure B-1. Registers within A16 Address Space

1. The subscript "h" at the end of the address indicates a hexadecimal number.

A16 Address Space Inside the Command Module or Mainframe

When the A16 address space is inside the HP E1406A Command module (Figure B-2), the multiplexer's base address is computed as:

$$1FC000_h + (LADDR * 64)_h$$

or (decimal)

$$2,080,768 + (LADDR * 64)$$

where $1FC000_h$ (2,080,768) is the starting location of the VXI A16 addresses, LADDR is the multiplexer's logical address, and 64 is the number of address bytes per register-based device. Again, the multiplexer's factory set logical address is 112. If this address is not changed, the multiplexer will have a base address of:

$$1FC000_h + (112 * 64)_h = 1FC000_h + 1C00_h = 1FDC00_h$$

or (decimal)

$$2,080,768 + (112 * 64) = 2,080,768 + 1536 = 2,087,936$$

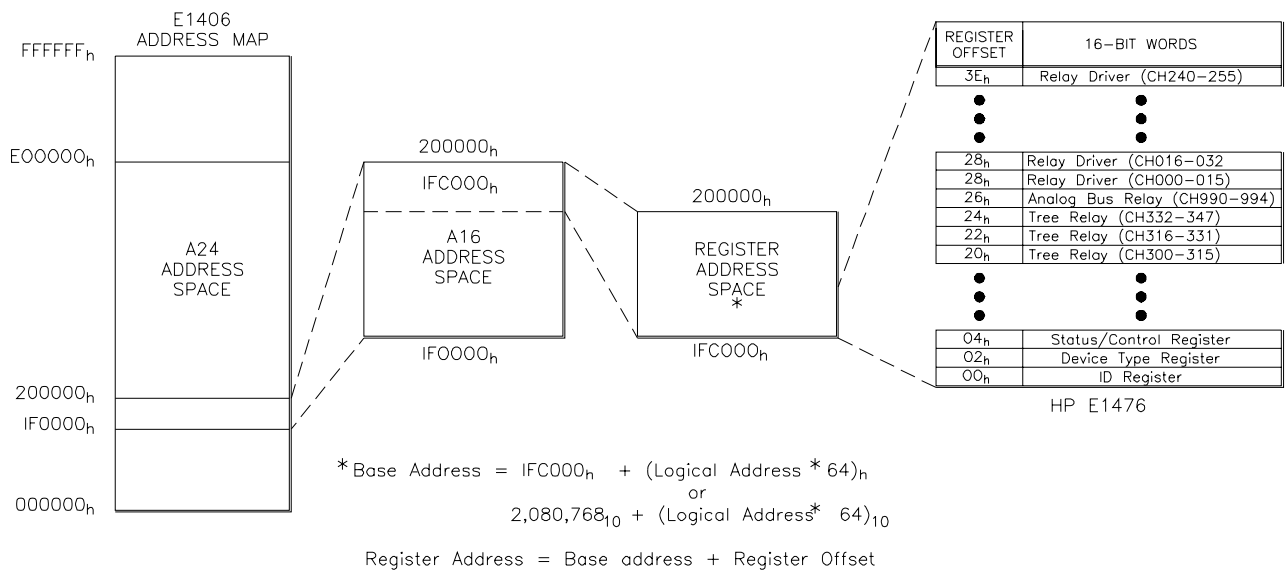

Figure B-2. Registers within Command Module's A16 Address Space

Register Offset

The register offset is the register's location in the block of 64 address bytes. For example, the multiplexer's Status/Control Register has an offset of 04_h . When you write a command to this register, the offset is added to the base address to form the register address:

$$DC00_h + 04_h = DC04_h$$

$$1FDC00_h + 04_h = 1FDC04_h$$

or (decimal)

$$56,320 + 4 = 56,324$$

$$2,087,936 + 4 = 2,087,940$$

Register Descriptions

The Multiplexer has 25 registers (refer to Table B-1). This section contains a description of each register. Undefined register bits appear as "1" when the register is read, and have no effect when written to.

Table B-1. HP E8462A 256-Channel Multiplexer Registers

Register	Addr. Offset	R/W	Register Description (Register Address)
ID Register	00 _h	R	MFG ID Register (Base + 00 _h)
Device Type Register	02 _h	R	Device Type Register (Base + 02 _h)
Status/Control Register	04 _h	R/W	Status/Control Register (Base + 04 _h)
Offset Register 14	06 _h	R/W	Offset Register (Base + 06 _h)
Analog Bus Relay Register 3	1E _h	R/W	Analog Bus Register (CH 990 - 994) (Base + 1E _h)
Relay Control Register 0	20 _h	R/W	Bank 0 (CH 000 - 015, 032 - 047) (Base + 20 _h)
Relay Control Register 1	22 _h	R/W	Bank 1 (CH 016 - 031, 048 - 063) (Base + 22 _h)
Relay Control Register 2	24 _h	R/W	Bank 2 (CH 064 - 079, 096 - 111) (Base + 24 _h)
Relay Control Register 3	26 _h	R/W	Bank 3 (CH 080 - 095, 112 - 127) (Base + 26 _h)
Relay Control Register 4	28 _h	R/W	Bank 4 (CH 128 - 143, 160 - 175) (Base + 28 _h)
Relay Control Register 5	2A _h	R/W	Bank 5 (CH 144 - 159, 176 - 191) (Base + 2A _h)
Relay Control Register 6	2C _h	R/W	Bank 6 (CH 192 - 207, 224 - 239) (Base + 2C _h)
Relay Control Register 7	2E _h	R/W	Bank 7 (CH 208 - 223, 240 - 255) (Base + 2E _h)
Tree Relay Control Register 0	30 _h	R/W	Tree Relay Bank 0 (CH 9000 - 9015) (Base + 30 _h)
Tree Relay Control Register 1	32 _h	R/W	Tree Relay Bank 1 (CH 9016 - 9021, 9100 - 9108) (Base + 32 _h)
Analog Bus Register 2	34 _h	R/W	Analog Bus (CH 9200 - 9204) (Base + 34 _h)
Timer Configuration Register 8	36 _h	R/W	Timer Configuration (Base + 36 _h)

You can write to the writable (W) registers and read from the readable (R) registers which are listed in Table B-1.

There are 8 relay registers driving the 256 channels of the Multiplexer and 2 tree relay registers controlling the 21 tree relays. The analog bus register controls 5 analog bus connection relays. All these relay control registers are readable/writable (R/W) registers. Writing a “1” to one bit will close the respective relay and writing a “0” will open the relay.

When power-on or reset the Multiplexer, all the control relays are open and when you read from these registers, all the bits are zero.

ID Register Reading the ID register returns $FFFF_h$ indicating the manufacturer is Hewlett-Packard and the module is an A16 register-based device.

base + 00_h	15	14	13	12	11	10	9	8	7	6	5	4	3	2	1	0
Write	Undefined								Logical Address							
Read	Manufacturer ID - returns $FFFF_h$ in Hewlett-Packard A16 only register-based card															

The “Programming Example” on page 108 shows how to read the ID Register.

Device Type Register Reading the Device Type Register returns $026B_h$ (decimal = 619) which identifies the device as the HP E8462A 256-Channel Relay Multiplexer.

base + 02_h	15	14	13	12	11	10	9	8	7	6	5	4	3	2	1	0
Write	Undefined															
Read	$026B_h, 619_{10}$															

The “Programming Example” on page 108 shows how to read the Device Type Register.

Status/Control Register Writing to the Status/Control Register (base + 04_h) enables you to disable/enable the interrupt generated when channels are closed or opened.

base + 04_h	15	14	13	12	11	10	9	8	7	6	5	4	3 - 0	
Write	Undefined					Set Interrupt Level			Undefined	D	Undefined	N	Reset All Relays	
Read	Undefined	M	Undefined	0	Interrupt Level			B	D	N		Undefined		

The “Programming Example” on page 108 shows how to read the Status Register.

Status/Control Register

Bits Defined:

*WRITE BITS (Control Register)	
bit 3, 2, 1, 0	Writing "1010" to bits 3, 2, 1, 0 resets the module to the power-on state (all channels open).
bit 4	Writing a "0" to this bit indicates there is some error during firmware testing. Writing a "0" to this bit will drive the yellow LED (DS102 on Opt 012) to light.
bit 6	Writing a "1" to this bit disables interrupt (generated by operating relay).
bits 10, 9, 8	Write bits 10, 9, 8 to set interrupt level. You can write bits 10, 9, 8 with 001, 010, 011, 100, 101, 110, 111 to set the interrupt level equal to interrupt level 1-7. The highest interrupt level is 7, and the lowest is 1 (default value).

**READ BITS (Status Register)	
bit 4	"1" or "0" = this bit has been set to "1" or "0".
bit 6	"1" = interrupt disabled; "0" = interrupt enabled
bit 7	Busy Status. "0" = busy (relay is opening/closing); "1" = not busy (relay is open/closed).
bits 10, 9, 8	The returned value indicates the current interrupt level of the multiplexer.
bit 11	This bit is always "0" when read back.
bit14	MODID bit; value "0" indicates that this module has been selected.

Disable/Enable Interrupts

To disable the interrupt generated when channels are opened or closed, write a "1" to bit 6 of the Status/Control Register (base + 04_h). Refer to your command module's operating manual before disabling the interrupt. Interrupts must be enabled in order to use the module's driver.

Reading the Status/Control Register Module Status

Each relay requires about 500 μs execution time. During this period, the relay is "busy". Bit 7 of this register informs the system of a busy condition. The interrupt generated after a channel has been closed can be disabled. Bit 6 of this register is used to inform the user of the interrupt status.

As an example, if the Status Register (base + 04_h) returns "BDFF_h (10111011111111)" the multiplexer module is not busy (bit 7 set), and the module interrupts are disabled (bit 6 set).

Reset Status

After the Multiplexer is powered on or reset, the Status Register will return "F1FF_h (1111000111111111)" if you read it.

Offset Register

The Offset Register xxxxxxxxxxxxxxxxxxxxxxxxxxxx

Offset Register 8 (Base + 06_h)

base + 30 _h	15	14	13	12	11	10	9	8	7	6	5	4	3	2	1	0
Write	ch143	ch142	ch141	ch140	ch139	ch138	ch137	ch136	ch135	ch134	ch133	ch132	ch131	ch130	ch129	ch128
Read																

Relay Control Registers

Writing to the Relay Control Registers ($\text{base} + 18_h$ to $\text{base} + 3E_h$) allows you to open or close any one of the 256 channel relays or the 48 tree relays or five analog bus relays. Any number of relays per bank can be closed at a time.

For example, to connect both Bank 0 and Bank 2 to the analog bus, you need to write a “1” to bits 0 and 1 of the Tree Relay Register 0 ($\text{base} + 18_h$) to close Tree Relays 1 and 2, meanwhile, you need also write a “1” to bit 0 of the Analog Bus Register ($\text{base} + 1E_h$) to close the analog bus control relay 49. All other bits are set to “0”.

The Relay Control Registers bit definitions are listed as below:

Bank 0 Channels 000 - 015 Relay Control Register 0 ($\text{base} + 20_h$)

$\text{base} + 20_h$	15	14	13	12	11	10	9	8	7	6	5	4	3	2	1	0
Write																
Read	ch015	ch014	ch013	ch012	ch011	ch010	ch009	ch008	ch007	ch006	ch005	ch004	ch003	ch002	ch001	ch000

Bank 1 Channels 000 - 015 Relay Control Register 1 ($\text{base} + 22_h$)

$\text{base} + 22_h$	15	14	13	12	11	10	9	8	7	6	5	4	3	2	1	0
Write																
Read	ch015	ch014	ch013	ch012	ch011	ch010	ch009	ch008	ch007	ch006	ch005	ch004	ch003	ch002	ch001	ch000

Bank 2 Channels 000 - 015 Relay Control Register 2 ($\text{base} + 24_h$)

$\text{base} + 24_h$	15	14	13	12	11	10	9	8	7	6	5	4	3	2	1	0
Write																
Read	ch047	ch046	ch045	ch044	ch043	ch042	ch041	ch040	ch039	ch038	ch037	ch036	ch035	ch034	ch033	ch032

Bank 3 Channels 000 - 015 Relay Control Register 3 ($\text{base} + 26_h$)

$\text{base} + 26_h$	15	14	13	12	11	10	9	8	7	6	5	4	3	2	1	0
Write																
Read	ch063	ch062	ch061	ch060	ch059	ch058	ch057	ch056	ch055	ch054	ch053	ch052	ch051	ch050	ch049	ch048

Bank 4 Channel 000 - 015 Relay Control Register 4 ($\text{Base} + 28_h$)

$\text{base} + 28_h$	15	14	13	12	11	10	9	8	7	6	5	4	3	2	1	0
Write																
Read	ch079	ch078	ch077	ch076	ch075	ch074	ch073	ch072	ch071	ch070	ch069	ch068	ch067	ch066	ch065	ch064

Bank 5 Channel 000 - 015 Relay Control Register 5 (Base + 2A_n)

base + 2A _n	15	14	13	12	11	10	9	8	7	6	5	4	3	2	1	0
Write	ch095	ch094	ch093	ch092	ch091	ch090	ch089	ch088	ch087	ch086	ch085	ch084	ch083	ch082	ch081	ch080
Read																

Bank 6 Channel 000 - 015 Relay Control Register 6 (Base + 2C_n)

base + 2C _n	15	14	13	12	11	10	9	8	7	6	5	4	3	2	1	0
Write	ch111	ch110	ch109	ch108	ch107	ch106	ch105	ch104	ch103	ch102	ch101	ch100	ch099	ch098	ch097	ch096
Read																

Bank 7 Channel 000 - 015 Relay Control Register 7 (Base + 2E_n)

base + 2E _n	15	14	13	12	11	10	9	8	7	6	5	4	3	2	1	0
Write	ch127	ch126	ch125	ch124	ch123	ch122	ch121	ch120	ch119	ch118	ch117	ch116	ch115	ch114	ch113	ch112
Read																

Tree Bank 0 Channel 9000 - 9015 Tree Relay Control Register 0 (Base + 30_n)

base + 18 _n	15	14	13	12	11	10	9	8	7	6	5	4	3	2	1	0
Write	ch315	ch314	ch313	ch312	ch311	ch310	ch309	ch308	ch307	ch306	ch305	ch304	ch303	ch302	ch301	ch300
Read																

Tree Bank 0 Channel 9000 - 9015 Tree Relay Control Register 0 (Base + 30_n)

base + 18 _n	15	14	13	12	11	10	9	8	7	6	5	4	3	2	1	0
Write	ch315	ch314	ch313	ch312	ch311	ch310	ch309	ch308	ch307	ch306	ch305	ch304	ch303	ch302	ch301	ch300
Read																

Tree Bank 1 Channel 9016 - 9021 and 9100 - 9108 Tree Relay Control Register 1 (Base + 32_n)

base + 1A _n	15	14	13	12	11	10	9	8	7	6	5	4	3	2	1	0
Write	ch331	ch330	ch329	ch328	ch327	ch326	ch325	ch324	ch323	ch322	ch321	ch320	ch319	ch318	ch317	ch316
Read																

Channel 9200 - 9204 Analog Bus Control Register 2 (Base + 34_h)

base + 1A _h	15	14	13	12	11	10	9	8	7	6	5	4	3	2	1	0
Write	ch347	ch346	ch345	ch344	ch343	ch342	ch341	ch340	ch339	ch338	ch337	ch336	ch335	ch334	ch333	ch332
Read																

Timer Configuration Control Register (Base + 36_h)

base + 1E _h	15	14	13	12	11	10	9	8	7	6	5	4	3	2	1	0
Write	Undefined											ch994	ch993	ch992	ch991	ch990
Read																

- Write a “1” to close a channel and write a “0” to open a channel.
- Reading the returns the state of the relay driver circuit only. It cannot detect a defective relay.

Resetting the Multiplexer

There are two ways to reset the Multiplexer:

You can either simply write a “0” to all bits in the Relay Control Registers or write “1010” to bits 3, 2, 1, 0 in the Status/Control Register to reset the Multiplexer.

Reading the Relay Control Registers

Reading the Relay Control Registers returns a hexadecimal number. A bit that is “1” represents a channel or a tree relay or one analog bus relay is closed. A bit that is “0” indicates the channel or the tree relay is open.

Program Timing and Execution

This section contains flowcharts and comments for using register programming to close/open channels and synchronize the multiplexer with a multimeter. The flowcharts identify the registers used and the status bits monitored to ensure execution of the program.

Closing Channels

The following flowchart shows how to close (or open) a multiplexer channel and determine when it has finished closing (or opening).

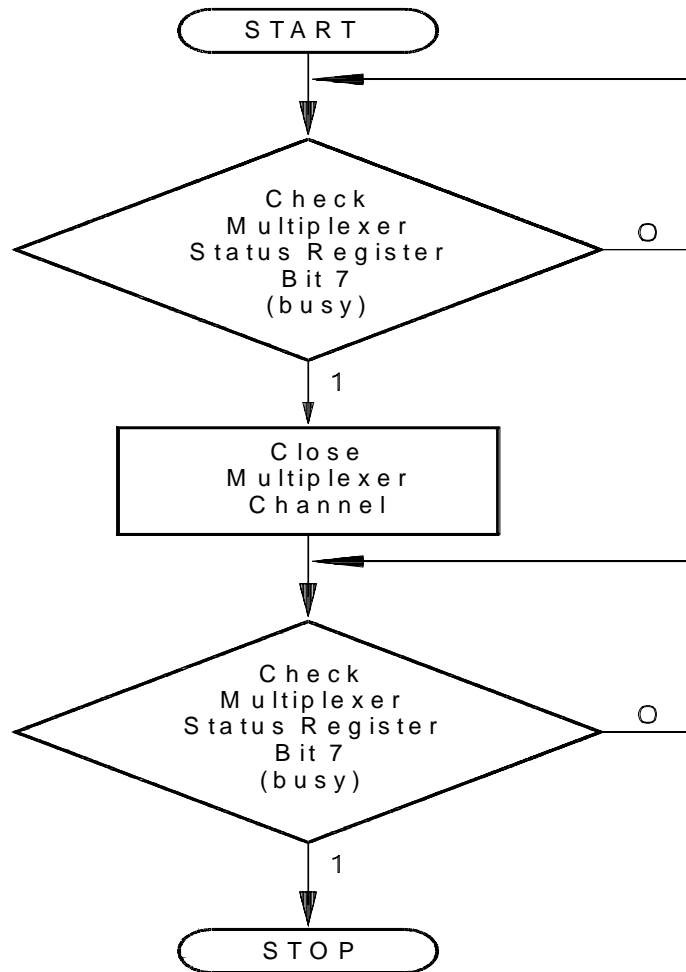

Figure B-3. Closing/Opening a Multiplexer channel

Comments

- The address of the multiplexer Status Register is $\text{base} + 04_h$. The address of the channel register is the base address plus the channel register offset.
- Multiplexer Status Register bit 7 (the BUSY bit) is monitored to determine when a multiplexer channel can be closed (or opened), and when a channel has finished closing (or opening).

Using a Multimeter with the Multiplexer

This flowchart shows the timing sequence between closing an HP E8462A Multiplexer channel and triggering an HP E1326/E1411 multimeter.

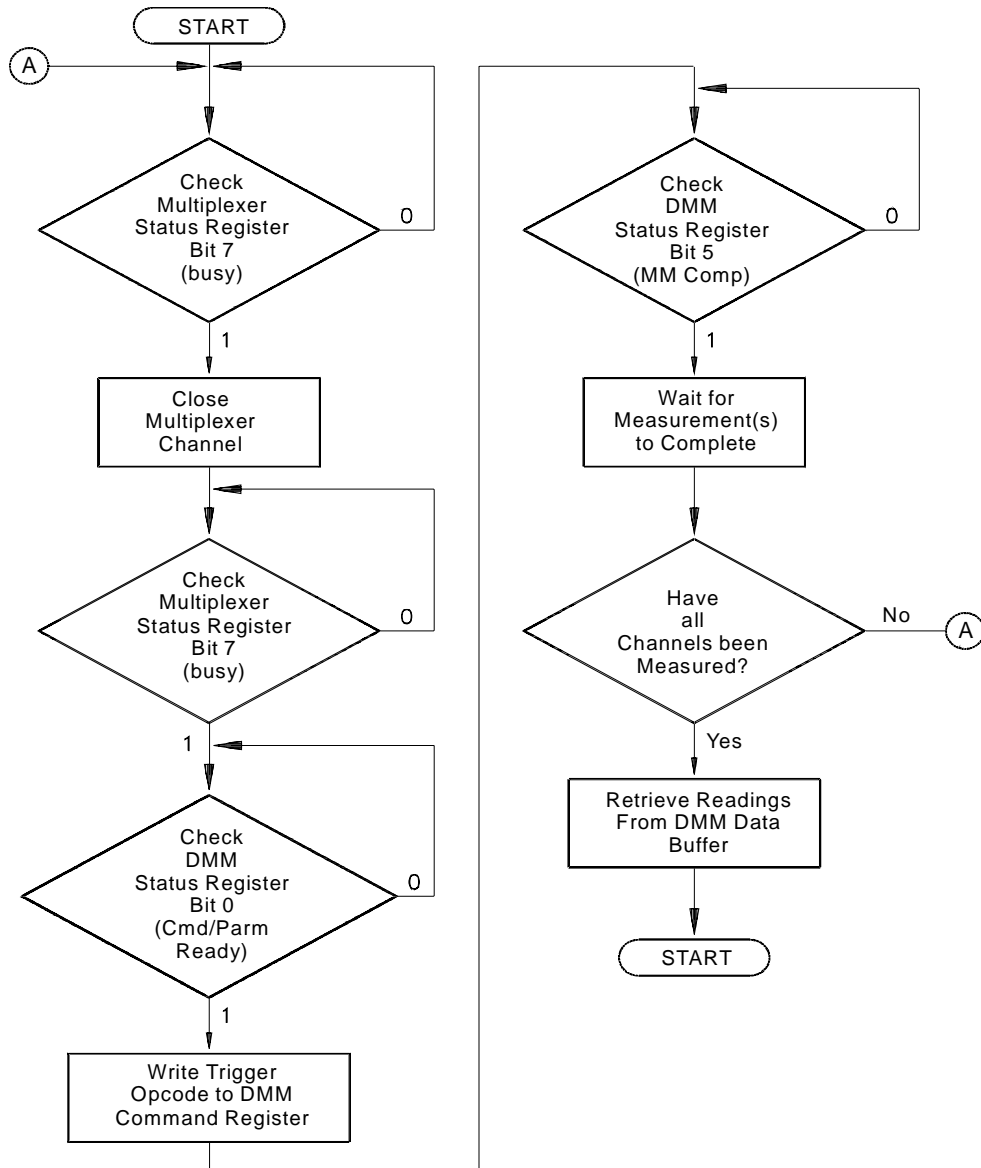

Figure B-4. Program Timing Between Multiplexer and Multimeter

Comments

- Multiplexer Status Register bit 7 (BUSY bit) is monitored to determine when a channel can be closed (or opened), and when a channel has finished closing (or opening).
- Multimeter status bit 0 (ready for command) is monitored to determine when a trigger opcode can be written to the Command Register (flowchart assumes the multimeter is already configured).

- Multimeter status bit 5 (multimeter complete) is monitored to determine when the analog-to-digital (A/D) conversion is in progress, and thus, when to advance the channel. This enables each channel to be measured before the readings are read from the buffer. The channel can also be advanced by monitoring bit 4 (Data Ready). However, before measuring the next channel, readings from the previous channel must be read from the buffer in order to clear the bit.
- Multimeter Autozero is often turned on in order to detect when bit 5 is active.

Programming Example

The example in this section demonstrate how to program the multiplexer in register format. This example includes:

- Reading the ID, Device Type, and Status Registers
- Closing/Opening a channel, Stand-Alone Multiplexer Measurements
- Scanning through channels

System Configuration

The following programs were developed on an embedded controller using Visual C/C++ programming language and using the SICL interface library. You can also use an external PC connected via HP-IB to an HP E1406A Command Module. The command module simply provides direct access to the VXI backplane.

Example Program

The following example program contains segments that:

- Read the ID and Device Type Registers.
- Read the Status Register.
- Close a group of channels and the associated tree relay.
- Resets the module to open all channels.
- Scans through all the channels on the module.

Beginning of Program

```
/* This program resets the E8462A, reads the ID Register, reads the Device */
/* Type Register, closes tree relays and channels and reads the multiplexer's */
/* Relay Control Registers, opens channels and scans all 256 channels on the */
/* (Visual C/C++ program using HP SICL I/O calls.) */
#include <sicl.h>
#include <stdio.h>
#include <stdlib.h>
#include <math.h>
#include <dos.h>

/* function prototypes */
void reset_mux(char *base_addr),
void delay (unsigned milliseconds);
```

Program Main

```
void main(void)
{ double ldexp(double i, int exp);
  char *base_addr;
  int j, k;
  unsigned short chan_0_15_reg, chan_16_31_reg; /* Bank 0-1 channels */
  unsigned short chan_32_47_reg, chan_48_63_reg; /* Bank 2-3 channels */
  unsigned short chan_64_79_reg, chan_80_95_reg; /* Bank 4-5 channels */
  unsigned short chan_96_111_reg, chan_112_127_reg; /* Bank 6-7 channels */
  unsigned short chan_128_143_reg, chan_144_159_reg; /* Bank 8-9 channels */
  unsigned short chan_160_175_reg, chan_176_191_reg; /* Bank 10-11 channels */
  unsigned short chan_192_207_reg, chan_208_223_reg; /* Bank 12-13 channels */
  unsigned short chan_224_239_reg, chan_240_255_reg; /* Bank 14-15 channels */
  unsigned short chan_300_315_reg, chan_316_331_reg; /* Tree bank 0-1 relays */
  unsigned short chan_332_347_reg, chan_348_352_reg; /* Tree bank 2-3 relays */
  unsigned short id_reg, dt_reg; /* ID and Device Type */
  unsigned short stat_reg; /* Status Register */

  /* create and open a device session */
  INST E8462A; E8462A = iopen("vxi,112");

  /* map the E8462A registers into user memory space */
  base_addr = imap(E8462A, I_MAP_VXIDEV, 0, 1, NULL);

  /* clear the user screen */
  clrscr();

  /* reset the E8462A */
  reset_mux(base_addr);
```

Read ID and Device Type Registers

```
/****** read the multiplexer's ID and Device Type registers *****/

id_reg = iwpeek((unsigned short *) (base_addr + 0x00));
dt_reg = iwpeek((unsigned short *) (base_addr + 0x02));
printf("ID register = 0x%4X\nDevice Type register = 0x%4X\n",
id_reg, dt_reg);
```

Read Status Register

```
/****** read the multiplexer's status register *****/

stat_reg = ipeek((unsigned short*)(base_addr + 0x04));
printf("Status register = 0x%4X\n", stat_reg);
```

Close and Open channels

```
/****** close and open channels *****/

/* close channels 0-15 by setting all bits in register (base + 0x20) to 1 */
iwpoke((unsigned short*)(base_addr + 0x20), 0xffff);

/* write a 1 to the register for tree relay 300 (base + 0x18) */
/* so channels 0-15 can be connected to the analog bus */
iwpoke((unsigned short*)(base_addr + 0x28), 1);

/* read the E8462A relay control registers and print their value */

chan_0_15_reg = ipeek((unsigned short*)(base_addr + 0x20));
chan_16_31_reg = ipeek((unsigned short*)(base_addr + 0x22));
chan_32_47_reg = ipeek((unsigned short*)(base_addr + 0x24));
chan_48_63_reg = ipeek((unsigned short*)(base_addr + 0x26));
chan_64_79_reg = ipeek((unsigned short*)(base_addr + 0x28));
chan_80_95_reg = ipeek((unsigned short*)(base_addr + 0x2A));
chan_96_111_reg = ipeek((unsigned short*)(base_addr + 0x2C));
chan_112_127_reg = ipeek((unsigned short*)(base_addr + 0x2E));
chan_128_143_reg = ipeek((unsigned short*)(base_addr + 0x30));
chan_144_159_reg = ipeek((unsigned short*)(base_addr + 0x32));
chan_160_175_reg = ipeek((unsigned short*)(base_addr + 0x34));
chan_176_191_reg = ipeek((unsigned short*)(base_addr + 0x36));
chan_192_207_reg = ipeek((unsigned short*)(base_addr + 0x38));
chan_208_223_reg = ipeek((unsigned short*)(base_addr + 0x3A));
chan_224_239_reg = ipeek((unsigned short*)(base_addr + 0x3C));
chan_240_255_reg = ipeek((unsigned short*)(base_addr + 0x3E));
chan_300_315_reg = ipeek((unsigned short*)(base_addr + 0x18));
chan_316_331_reg = ipeek((unsigned short*)(base_addr + 0x1A));
chan_332_347_reg = ipeek((unsigned short*)(base_addr + 0x1C));
chan_348_352_reg = ipeek((unsigned short*)(base_addr + 0x1E));

printf("channels 00-15 register = 0x%4X\n", chan_0_15_reg);
printf("channels 16-31 register = 0x%4X\n", chan_16_31_reg);
printf("channels 32-47 register = 0x%4X\n", chan_32_47_reg);
printf("channels 48-63 register = 0x%4X\n", chan_48_63_reg);
printf("channels 64-79 register = 0x%4X\n", chan_64_79_reg);
printf("channels 80-95 register = 0x%4X\n", chan_80_95_reg);
printf("channels 96-111 register = 0x%4X\n", chan_96_111_reg);
printf("channels 112-127 register = 0x%4X\n", chan_112_127_reg);
printf("channels 128-143 register = 0x%4X\n", chan_128_143_reg);
printf("channels 144-159 register = 0x%4X\n", chan_144_159_reg);
printf("channels 160-175 register = 0x%4X\n", chan_160_175_reg);
printf("channels 176-191 register = 0x%4X\n", chan_176_191_reg);
printf("channels 192-207 register = 0x%4X\n", chan_192_207_reg);
printf("channels 208-223 register = 0x%4X\n", chan_208_223_reg);
```

```

printf("channels 224-239 register = 0x%4X\n", chan_224_239_reg);
printf("channels 240-255 register = 0x%4X\n", chan_240_255_reg);

printf("channels 300-315 (tree) register = 0x%4X\n", chan_300_315_reg);
printf("channels 316-331 (tree) register = 0x%4X\n", chan_316_331_reg);
printf("channels 332-347 (tree) register = 0x%4X\n", chan_332_347_reg);
printf("channels 348-352 (tree) register = 0x%4X\n", chan_348_352_reg);
delay (2000); /* waits 2 seconds before resetting mux */

/* reset the E8462A to open all closed channels */
/* writing a 0 to the channels registers will also open channels */
reset_mux(base_addr);

```

Scan channels

```

/***** scanning channels *****/

/* scan channels 0-15 in relay driver bank 0 (register offset 0x20) */
for (k=0; k<=15; k++)
{
iwpoke ((unsigned short *)(base_addr + 0x20), ldexp(1,k));
/* take measurement here after each iteration of the loop */
}
/* set all bits to 0 to open last closed channel */
iwpoke ((unsigned short *)(base_addr + 0x20), 0);

/* scan channels 16-31 in relay driver bank 1 (register offset 0x22) */
for (k=0; k<=15; k++)
{
iwpoke ((unsigned short *)(base_addr + 0x22), ldexp(1,k));
/* take measurement here after each iteration of the loop */
}
/* set all bits to 0 to open last closed channel */
iwpoke ((unsigned short *)(base_addr + 0x22), 0);

/* scan channels 32-47 in relay driver bank 2 (register offset 0x24) */
for (k=0; k<=15; k++)
{
iwpoke ((unsigned short *)(base_addr + 0x24), ldexp(1,k));
/* take measurement here after each iteration of the loop */
}
/* set all bits to 0 to open last closed channel */
iwpoke ((unsigned short *)(base_addr + 0x24), 0);

/* scan channels 48-63 in relay driver bank 3 (register offset 0x26) */
for (k=0; k<=15; k++)
{
iwpoke ((unsigned short *)(base_addr + 0x26), ldexp(1,k));
/* take measurement here after each iteration of the loop */
}
/* set all bits to 0 to open last closed channel */
iwpoke ((unsigned short *)(base_addr + 0x26), 0);

/* scan channels 64-79 in relay driver bank 4 (register offset 0x28) */
for (k=0; k<=15; k++)

```

```

{
iwpoke ((unsigned short *)(base_addr + 0x28), ldexp(1,k));
/* take measurement here after each iteration of the loop */
}
/* set all bits to 0 to open last closed channel */
iwpoke ((unsigned short *)(base_addr + 0x28), 0);

/* scan channels 80-95 in relay driver bank 5 (register offset 0x2A) */
for (k=0; k<=15; k++)
{
iwpoke ((unsigned short *)(base_addr + 0x2A), ldexp(1,k));
/* take measurement here after each iteration of the loop */
}
/* set all bits to 0 to open last closed channel */
iwpoke ((unsigned short *)(base_addr + 0x2A), 0);

/* scan channels 96-111 in relay driver bank 6 (register offset 0x2C) */
for (k=0; k<=15; k++)
{
iwpoke ((unsigned short *)(base_addr + 0x2C), ldexp(1,k));
/* take measurement here after each iteration of the loop */
}
/* set all bits to 0 to open last closed channel */
iwpoke ((unsigned short *)(base_addr + 0x2C), 0);

/* scan channels 112-127 in relay driver bank 7 (register offset 0x2E) */
for (k=0; k<=15; k++)
{
iwpoke ((unsigned short *)(base_addr + 0x2E), ldexp(1,k));
/* take measurement here after each iteration of the loop */
}
/* set all bits to 0 to open last closed channel */
iwpoke ((unsigned short *)(base_addr + 0x2E), 0);

/* scan channels 128-143 in relay driver bank 8 (register offset 0x30) */
for (k=0; k<=15; k++)
{
iwpoke ((unsigned short *)(base_addr + 0x30), ldexp(1,k));
/* take measurement here after each iteration of the loop */
}
/* set all bits to 0 to open last closed channel */
iwpoke ((unsigned short *)(base_addr + 0x30), 0);

/* scan channels 144-159 in relay driver bank 9 (register offset 0x32) */
for (k=0; k<=15; k++)
{
iwpoke ((unsigned short *)(base_addr + 0x32), ldexp(1,k));
/* take measurement here after each iteration of the loop */
}
/* set all bits to 0 to open last closed channel */
iwpoke ((unsigned short *)(base_addr + 0x32), 0);

/* scan channels 160-175 in relay driver bank 10 (register offset 0x34) */
for (k=0; k<=15; k++)

```



```

{
iwpoke ((unsigned short *)(base_addr + 0x34), ldexp(1,k));
/* take measurement here after each iteration of the loop */
}
/* set all bits to 0 to open last closed channel */
iwpoke ((unsigned short *)(base_addr + 0x34), 0);

/* scan channels 176-191 in relay driver bank 11 (register offset 0x36) */
for (k=0; k<=15; k++)
{
iwpoke ((unsigned short *)(base_addr + 0x36), ldexp(1,k));
/* take measurement here after each iteration of the loop */
}
/* set all bits to 0 to open last closed channel */
iwpoke ((unsigned short *)(base_addr + 0x36), 0);

/* scan channels 192-207 in relay driver bank 12 (register offset 0x38) */
for (k=0; k<=15; k++)
{
iwpoke ((unsigned short *)(base_addr + 0x38), ldexp(1,k));
/* take measurement here after each iteration of the loop */
}
/* set all bits to 0 to open last closed channel */
iwpoke ((unsigned short *)(base_addr + 0x38), 0);

/* scan channels 208-223 in relay driver bank 13 (register offset 0x3A) */
for (k=0; k<=15; k++)
{
iwpoke ((unsigned short *)(base_addr + 0x3A), ldexp(1,k));
/* take measurement here after each iteration of the loop */
}
/* set all bits to 0 to open last closed channel */
iwpoke ((unsigned short *)(base_addr + 0x3A), 0);

/* scan channels 224-239 in relay driver bank 14 (register offset 0x3C) */
for (k=0; k<=15; k++)
{
iwpoke ((unsigned short *)(base_addr + 0x3C), ldexp(1,k));
/* take measurement here after each iteration of the loop */
}
/* set all bits to 0 to open last closed channel */
iwpoke ((unsigned short *)(base_addr + 0x3C), 0);

/* scan channels 240-255 in relay driver bank 15 (register offset 0x3E) */
for (k=0; k<=15; k++)
{
iwpoke ((unsigned short *)(base_addr + 0x3E), ldexp(1,k));
/* take measurement here after each iteration of the loop */
}
/* set all bits to 0 to open last closed channel */
iwpoke ((unsigned short *)(base_addr + 0x3E), 0);

/* close HP SICL session */
iclose(E8462A);

```

```
} /* end of main */
```

Reset Function

```
/******  
void reset_mux(char *base_addr)  
    /* reset the mux to open all relays (write a 1 to status bit 0)*/  
    /* delay 100 ms for reset then set bit to 0 to allow closing*/  
    /* switches          */  
{  
    /* this function resets the multiplexer */  
    iwpoke((unsigned short*)(base_addr + 0x04), 1);  
    delay (100); /* must wait at least 100 usec before writing a "0" */  
    iwpoke((unsigned short*)(base_addr + 0x04), 0); } }
```

Program Output Printout from example program:

```
ID register = 0xFFFF  
Device Type register = 0x 265  
Status register = 0xFFBE  
channels 00-15 register = 0xFFFF  
channels 16-31 register = 0x 0  
channels 32-47 register = 0x 0  
channels 48-63 register = 0x 0  
channels 64-79 register = 0x 0  
channels 80-95 register = 0x 0  
channels 96-111 register = 0x 0  
channels 112-127 register = 0x 0  
channels 128-143 register = 0x 0  
channels 144-159 register = 0x 0  
channels 160-175 register = 0x 0  
channels 176-191 register = 0x 0  
channels 192-207 register = 0x 0  
channels 208-223 register = 0x 0  
channels 224-239 register = 0x 0  
channels 240-255 register = 0x 0  
channels 300-315 register = 0x 0  
channels 316-331 register = 0x 0  
channels 332-347 register = 0x 0  
channels 348-353 register = 0x 0
```

Appendix C

Error Messages

Error Types

Table C-2 lists the error messages generated by the HP E8460A Relay Multiplexer module firmware when programmed by SCPI. Errors with negative values are governed by the SCPI standard and are categorized in Table C-1. Error numbers with positive values are not governed by the SCPI standard.

Table C-1. Error Types Described

Number Range	Error Types Description
-199 to -100	Command Errors (syntax and parameter errors). See the <i>HP E1405/E1406 Command Module User's Manual</i> for a description of these errors.
-299 to -200	Execution Errors (instrument driver detected errors). See the <i>HP E1405/E1406 Command Module User's Manual</i> for further details.
-399 to -300	Device Specific Errors (instrument driver errors that are not command nor execution errors). See the <i>HP E1405/E1406 Command Module User's Manual</i> for further details.
-499 to -400	Query Errors (problem in querying an instrument). See the <i>HP E1405/E1406 Command Module User's Manual</i> for description of these errors.

"Table C-2. Multiplexer Error Messages" appears in its entirety on the following page.

Table C-2. Multiplexer Error Messages

Code	Error Message	Potential Cause(s)
-211	Trigger ignored	Trigger received when scan not enabled. Trigger received after scan complete. Trigger too fast.
-213	Init Ignored	Attempting to execute an INIT command when a scan is already in progress.
-222	Data out of range	Parameter value is outside valid range.
-224	Illegal parameter value	Attempting to execute a command with a parameter not applicable to the command.
-240	Hardware error	Command failed due to a hardware problem.
-310	System error	Internal driver error. This error can result if an excessively long parameter list is entered.
1500	External trigger source already allocated	Assigning an external trigger source to a switchbox when the trigger source has already been assigned to another switchbox.
1510	Trigger source non-existent	Selected trigger source is not available on this platform (e.g. some triggers are not available on the E1300/E1301 VXi B-size mainframes).
2000	Invalid card number	Addressing a module (card) in a switchbox that is not part of the switchbox.
2001	Invalid channel number	Attempting to address a channel of a module in a switchbox that is not supported by the module (e.g., channel 99 of a multiplexer module).
2006	Command not supported on this card	Sending a command to a module (card) in a switchbox that is unsupported by the module.
2008	Scan list not initialized	Executing a scan without the INIT command.
2009	Too many channels in channel list	Attempting to address more channels than available in the switchbox.
2010	Scan mode not allowed on this card	The selected scanning mode is not allowed with this module or you have misspelled the mode parameter (see SCAN:MODE command).
2011	Empty channel list	No valid channels are specified in the channel_list.
2012	Invalid Channel Range	Invalid channel(s) specified in SCAN <channel_list> command. Attempting to begin scanning when no valid channel list is defined.
2600	Function not supported on this card	Sending a command to a module (card) in a switchbox that is not supported by the module or switchbox.
2601	Channel list required	Sending a command requiring a channel_list without the channel_list.

A

A16 Address Space, [95, 95](#)
A16 Address Space Inside the Command Module, [97](#)
A16 Address Space Outside the Command Module,
[96](#)
Abbreviated Commands, [56](#)
ABORT, [58](#)
Address
 A16 address space, [95](#)
 base address, [95](#)
 channel, [29](#)
 logical, [96, 97, 97](#)
Addressing
 Register, [95](#)
Analog Bus
 connecting a channel to the, [37](#)
 scanning channels using the, [43](#)
 switching channels to the, [36](#)
ARM, [60, 60](#)
ARM:COUNT;SCPI Command Reference
 ARM:COUNT, [60](#)
ARM:COUNT?, [60](#)

B

Base Address, [95](#)
Bus
 connecting a channel to the analog, [37](#)
 scanning channels using the analog, [43](#)

C

Card Numbers, [30](#)
Channel
 lists, [31](#)
 ranges, [31](#)
Channel Address, [29](#)
Channel Lists, [31](#)
Channel Numbers, [31](#)
Channel Numbers, Ranges, and Lists, [31](#)
Channel Ranges, [31](#)
Channel Switching
 four-wire, [41](#)
 temperature measurements, [43](#)
 three-wire, [39](#)

Channels
 closing, [106](#)
 using BUS triggers with an external device to
 scan, [52](#)
Checking
 using interrupts with error, [54](#)
Closing
 tree relays, [102](#)
Closing Channels, [106](#)
Closures, Relay Maximum, [41](#)
Command, [96, 97](#)
Command Format
 common, [55](#)
 SCPI, [55](#)
Command Module
 A16 address space inside the, [97](#)
 A16 address space outside the, [96](#)
Command Reference
 IEEE 488.2 Common, [90](#)
 SCPI, [58, 58](#)
 Switchbox, [55](#)
Command Separator, [55](#)
Command Types, [55](#)
Commands
 abbreviated, [56](#)
 implied, [56](#)
 linking, [57](#)
 specifying SCPI, [29](#)
Common Command Format, [55](#)
Common Command Reference
 IEEE 488.2, [90](#)
Conditions
 detecting error, [54](#)
 reset, [35](#)
Configuring, [11, 11, 11, 11, 11, 11, 11](#)
Connecting a Channel to the Analog Bus, [37](#)
Connecting User Inputs, [18](#)

D

Descriptions
 register, [99](#)
Detecting Error Conditions, [54](#)
Disable/Enable Interrupts.Interrupts
 disable/enable, [101](#)

E

- Error Checking
 - using interrupts with, [54](#)
- Error Conditions
 - detecting, [54](#)
- Error Messages
 - multiplexer, [91](#), [115](#)
- Error Types, [115](#)
- Example Programs, [33](#)
- Examples
 - programming, [108](#)
- ExampleUsing the scan complete bit, [53](#)
- Execution
 - program, [106](#)

F

- Format
 - common command, [55](#)
 - SCPI command, [55](#)
- Four-Wire Channel Switching, [41](#)

I

- IEEE 488.2 Common Command Reference, [90](#)
- Implied Commands, [56](#)
- Initial Operation, [32](#)
- INITiate, [66](#)
- INITiate:CONTinuous, [66](#)
- INITiate:CONTinuous?, [67](#)
- INITiate[:IMMediate], [67](#)
- Inputs
 - connecting user, [18](#)

L

- LADDR, [96](#)
- Linking Commands, [57](#)
- Logical Address
 - factory setting, [96](#), [97](#), [97](#)
 - register-based, [96](#)
 - setting, [96](#), [97](#), [97](#)

M

- Maximum Relay Closures, [41](#)
- Messages
 - multiplexer error, [91](#), [115](#)
- Module
 - A16 address space inside the command, [97](#)
 - A16 address space outside the command, [96](#)
- Module ID, [33](#)

- Module Status
 - reading the status/control register, [101](#)
- Modules
 - terminal, [23](#)
- Multimeter
 - using a multiplexer with the, [107](#)
- Multiplexer
 - logical address, [96](#), [97](#), [97](#)
 - programming the, [29](#)
 - resetting the, [105](#)
 - using a multimeter with the, [107](#)
- Multiplexer Error Messages, [91](#), [115](#)
- Multiplexer Setup, [11](#), [11](#)

N

- Notes on Scanning, [46](#)
- Numbers
 - card, [30](#)
 - channel, [31](#)

O

- Opening
 - tree relays, [102](#)
- Operation
 - initial, [32](#)
- OUTPut, [68](#)
- OUTPut:ECLTrgn[:STATe]?, [68](#)
- OUTPut:TTLTrgn[:STATe], [70](#)
- OUTPut:TTLTrgn[:STATe]?, [70](#)
- OUTPut[:EXTernal][:STATe], [69](#)
- OUTPut[:EXTernal][:STATe]?, [69](#)

P

- Program execution, [106](#)
- Program Timing, [106](#)
- Program Timing and Execution, [106](#)
- Programming
 - Register-based, [95](#)
- Programming Examples, [108](#)
- Programming the Multiplexer, [29](#)
- Programs, Example, [33](#)

Q

- Quick Reference
 - SCPI Command, [89](#)

R

- Reading
 - registers, 95
- Reading the Relay Control Registers, 105
- Reading the Status/Control Register Module Status, 101
- Recalling and Saving States, 53
- Recalling States, 53
- Reference
 - SCPI Command Quick, 89
- Register
 - the device type, 100
 - the status/control, 100
- Register Addressing, 95
- Register Descriptions, 99
- Register-based Programming, 95
 - base address, 95
 - description, 95
- Registers
 - base address, 95
 - reading registers, 95
 - reading the relay control, 105
 - relay control, 102
 - the WRITE, 99
 - writing to registers, 95
- Relay
 - tree relays, 102
- Relay Closures, Maximum, 41
- Relay Control Registers, 102
- Reset, 33
- Reset Conditions, 35
- Resetting the Multiplexer, 105
- [ROUTE:], 71
- [ROUTE:]CLOSE, 71
- [ROUTE:]CLOSE?, 63, 73
- [ROUTE:]OPEN, 75
- [ROUTE:]OPEN?, 76
- [ROUTE:]SCAN, 76
- [ROUTE:]SCAN:MODE, 77
- [ROUTE:]SCAN:MODE?, 78
- [ROUTE:]SCAN:PORT, 78, 79

SCPI Command Reference

- [ROUTE:], 71
- [ROUTE:]CLOSE, 71
- [ROUTE:]CLOSE?, 63, 73
- [ROUTE:]OPEN, 75
- [ROUTE:]OPEN?, 76
- [ROUTE:]SCAN, 76
- [ROUTE:]SCAN:MODE, 77
- [ROUTE:]SCAN:MODE?, 78
- [ROUTE:]SCAN:PORT, 78, 79

S

- Saving States, 53
- Scan Channels
 - using BUS triggers with an external device to, 52
- Scan Complete Bit
 - using the example, 53
- Scanning, 36
 - notes on, 46
- Scanning Channels Using the Analog Bus, 43
- SCPI Command Format, 55
- SCPI Command Quick Reference, 89
- SCPI Command Reference, 58
 - ABORT, 58
 - ARM, 60
 - ARM:COUNT?, 60
 - INITiate, 66
 - INITiate:CONTinuous, 66
 - INITiate:CONTinuous?, 67
 - INITiate[:IMMEDIATE], 67
 - OUTPut, 68
 - OUTPut:ECLTrgn[:STATe]?, 68
 - OUTPut:TTLTrgn[:STATe], 70
 - OUTPut:TTLTrgn[:STATe]?, 70
 - OUTPut[:EXTernal][:STATe], 69
 - OUTPut[:EXTernal][:STATe]?, 69
 - STATus, 80

SCPI Command Reference (continued), 58

STATus:OPERation:CONDition?, 81

STATus:OPERation:ENABLE, 81

STATus:OPERation:ENABLE?, 81

STATus:OPERation[:EVENT]?, 82

STATus:PRESet, 82

SYSTem, 84

SYSTem:CDEscription?, 84

SYSTem:CPON, 84

SYSTem:CTYPe?, 85

SYSTem:ERRor?, 85

TRIGger, 86

TRIGger:SOURce, 87

TRIGger:SOURce?, 88

TRIGger[:IMMediate], 86

SCPI Commands

specifying, 29

Self Test, 33

Separator

command, 55

Setup

multiplexer, 11, 11

Specifying SCPI Commands, 29

States

recalling, 53

recalling and saving, 53

saving, 53

STATus, 80

STATus:OPERation:CONDition?, 81

STATus:OPERation:ENABLE, 81

STATus:OPERation:ENABLE?, 81

STATus:OPERation[:EVENT]?, 82

STATus:PRESet, 82

Switchbox Command Reference, 55

Switching, 36

four-wire channel, 41

temperature measurements by channel, 43

three-wire channel, 39

Switching Channels to the Analog Bus, 36

Switching or Scanning, 36

Synchronizing the Multimeter with a multiplexer, 46

Synchronizing the Multiplexer

with a multimeter, 46

Synchronizing the Multiplexer with a Multimeter, 46

SYSTem, 84

SYSTem:CDEscription?, 84

SYSTem:CPON, 84

SYSTem:CTYPe?, 85

SYSTem:ERRor?, 85

T

Temperature Measurements By Channel Switching, 43

Terminal Module

wiring a, 26

Terminal Modules, 23

The Device Type Register, 100

The Status/Control Register, 100

The WRITE Registers, 99

Three-Wire Channel Switching, 39

Timing

program, 106

Tree Relays

closing, 102

opening, 102

TRIGger, 86

TRIGger:SOURce, 87

TRIGger:SOURce?, 88

TRIGger[:IMMediate], 86

Types

command, 55

error, 115

U

User Inputs

connecting, 18

Using a Multimeter with the Multiplexer, 107

Using BUS Triggers with an External Device to Scan Channels, 52

Using Interrupts With Error Checking, 54

W

Wiring a Terminal Module, 26

Writing to Registers, 95